

# FREE SAMPLE: LETTER d

## ALPHABET CURRICULUM FOR PRESCHOOL

LETTERS, SOUNDS & PHONEMIC AWARENESS!

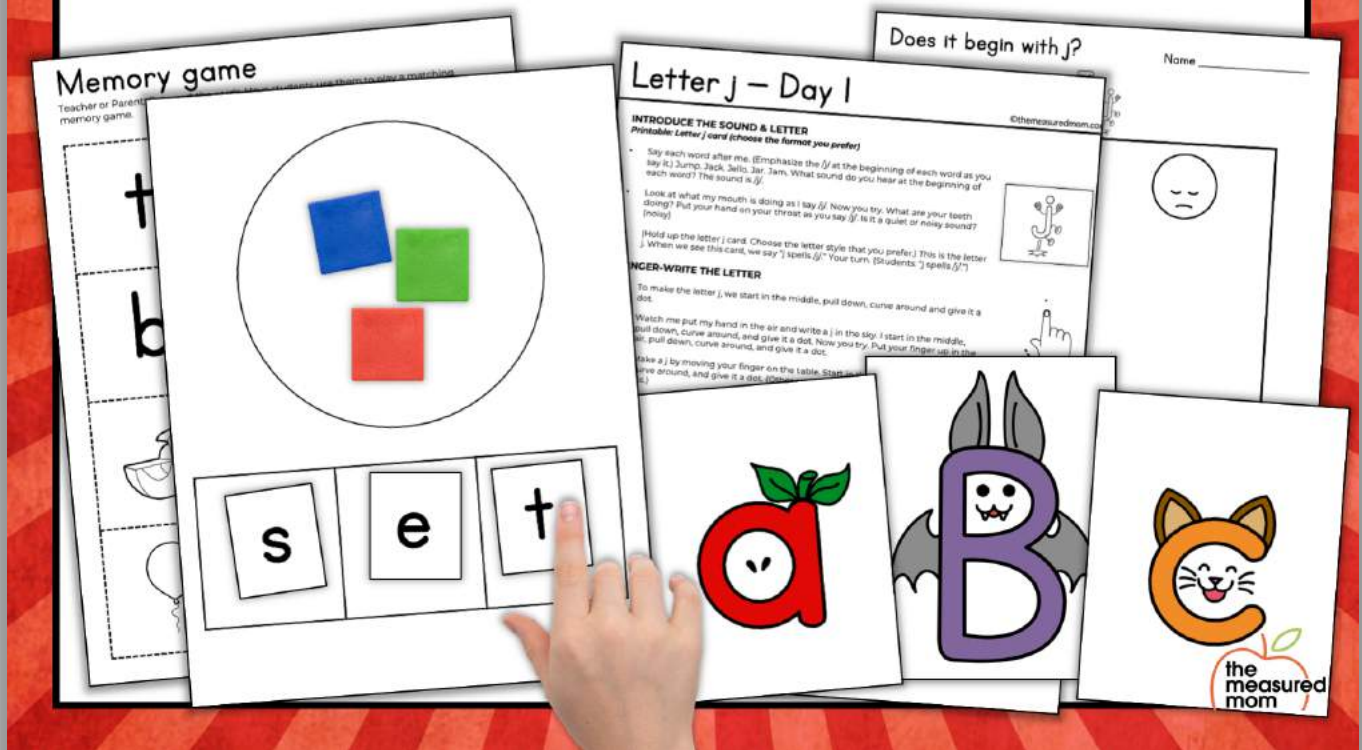

This is a FREE SAMPLE of The Measured Mom's Alphabet Curriculum for Preschool. You may purchase the full curriculum at this link.

# THANK YOU FOR YOUR PURCHASE!



If you're having trouble when printing the contents of this packet, you need the most current version of the free Adobe Reader on your computer. You can get it for free here:

<https://get.adobe.com/reader/>

## TERMS OF USE



*The unauthorized reproduction or distribution of a copyrighted work is illegal. Criminal copyright infringement, including infringement without monetary gain, is investigated by the FBI and is punishable by fines and federal imprisonment.*

This printable resource was created for you to use at home with your child/students or with multiple children in **your** classroom or tutoring setting.

However, you may not share this curriculum online. Please **DO NOT** share the file **OR** printed copies of the file with others. You may also not sell, host, reproduce, give away, or store on any other site (including a blog, Facebook, Dropbox, Course Hero, shared Google Drive, Amazon Inspire, etc.).

## CLIP ART CREDIT

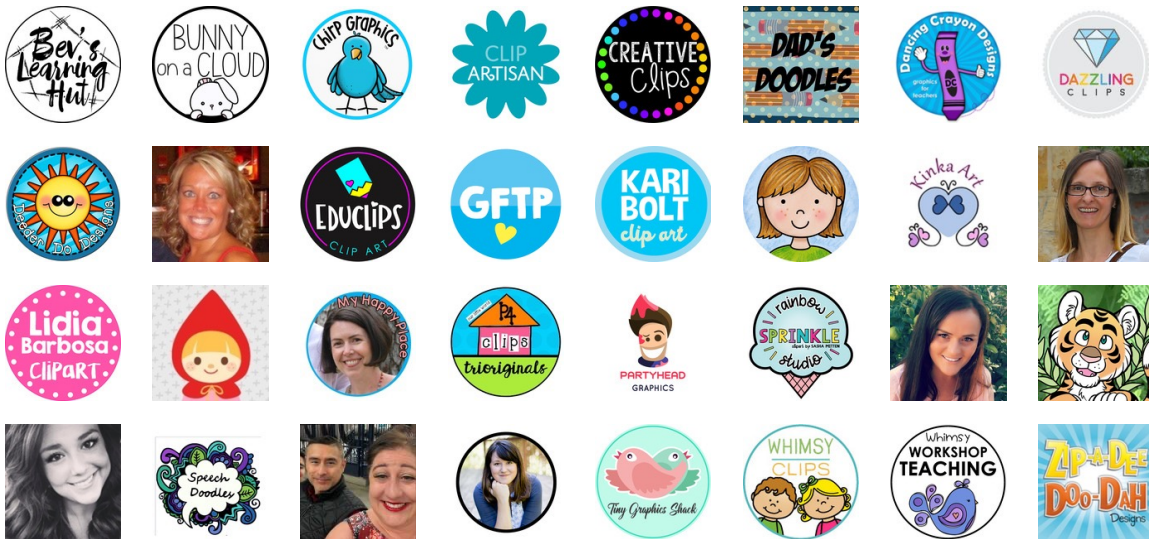

## Alphabet Curriculum for Preschool

© 2023 by Anna Geiger. All rights reserved worldwide.

[www.themeasuredmom.com](http://www.themeasuredmom.com)

ALL RIGHTS RESERVED. This digital file contains materials protected under International and Federal Copyright Laws and Treaties.

# HOW TO TEACH THE ALPHABET

## **Teach letter names and sounds together.**

Based on recent studies, researchers are beginning to agree that students benefit from learning letter names and sounds at the same time, rather than teaching one before the other. To learn more about this research, visit this blog post:

<https://www.themeasuredmom.com/should-we-teach-letter-names-or-letter-sounds-first/>

## **Use your best judgment when deciding to teach uppercase or lowercase first in preschool.**

According to Dr. Shayne Piasta, a major researcher in the field alphabet learning, there is correlational evidence that children may use uppercase knowledge to learn lowercase letters, but no studies have been conducted to determine which is best to teach first.

Preschool teachers everywhere are divided on this topic, which is why this curriculum includes both a lowercase set of lessons and an uppercase set of lessons. To learn more, visit this blog post: <https://www.themeasuredmom.com/whats-the-best-order-to-teach-letters/>

## **Research does not tell us the best order to teach letters.**

We are free to choose an order that best fits our goals. A major goal for this program is to help students form letters correctly. Because of that, we have chosen an order which groups letters with similar strokes. We have also separated letters and sounds which are easily confused.

The order for the lowercase letter curriculum is as follows:

t, l, i, j, u, r, n, m, h, b, p, o, c, d, a, g, q, s, f, e, z, v, w, k, y, x

## **Paired-associate learning is most effective when teaching the alphabet.**

This refers to directly telling children that a particular letter spells a particular sound. Research shows us that this direct approach is more effective than teaching letters indirectly through read alouds and crafts. While read alouds and crafts serve their own purpose, I recommend introducing and reviewing letters with mnemonic flash cards. Mnemonic flash cards, included in this program, have a picture embedded in each letter. Recent research has found that children have greater success learning letter sounds when the picture is embedded in the letter.

## **Routines are important for learning.**

You will notice routines that return each week. Routines are important for freeing working memory so that students can focus on learning the new skill. As you learn the lesson routines, you will also find that they make teaching easier!

## **Build in review.**

Each week's lessons include review using daily flash cards and a weekly game-type activity. Make the flash cards fun! Research tells us that the act of retrieval (such as naming the letter and sound on a card) improves retention.

# TEACHING TIPS

## **Overview**

Each week's lessons includes explicit instruction for teaching a letter's name and sound, review activities, an interactive read aloud, a phonological awareness activity, handwriting practice, vocabulary building, and phonemic awareness. You will notice routines that return each week. Routines are important for freeing working memory so that students can focus on learning the new skill.

## **Use each day's lesson script as a guide.**

You are welcome to follow the script exactly, but you will likely want to adjust it based on how your students respond. You should feel free to teach the lessons as you wish, but we do not recommend skipping items from the Day 1, 2, and 3 lesson pages.

## **Use these lessons with the whole class, in small groups, or one-on-one.**

These lessons are designed for whole class use, but they will also work very well with small groups or in a tutoring or homeschool setting.

## **Use these lessons in order.**

After Lesson 1, each week has a built-in review activity. These activities include letters that have been previously taught, which is why we recommend doing the lessons in order. If you choose to do the lessons out of order, you will want to create your own review activities.

## **Use the pacing that feels right to you.**

While teaching a letter per week is too slow for kindergarten, it can be just right for preschool as long as you review previously learned letters. Feel free to focus on one letter per week (3 complete lessons) or, if you have more than 3 school days in a week, one lesson per day.

## **Choose a different read aloud if you prefer.**

Day 1 of each letter includes an interactive read aloud with questions to ask before and after reading. Feel free to switch it out for a different book.

## **Make sure to pronounce letter sounds correctly.**

Whenever you see a letter between slash marks like this: /s/, say the letter's sound, not name. When pronouncing letter sounds, make sure not to add a schwa at the end. For example, for the sound of letter L, say "l l l l l" and not "luh." Teach your students learn to do the same.

## **Do associated crafts, science, and math activities only if you desire.**

These are not necessary for teaching a letter's name and sound. We have included the ideas because we know that some teachers like to include other activities that begin with a particular letter.

## **Use or skip any of the bonus printables.**

Each letter includes a set of optional bonus pages. These include letter find page, a block letter, road tracing letter formation, additional tracing pages, and more. Skip them completely if you'd like!

# Letter d – Day 1

## INTRODUCE THE SOUND & LETTER

**Printable: Letter d Card (choose the format you prefer)**

- Say each word after me. (Emphasize the /d/ at the beginning of each word as you say it.) Dinosaur. Duck. Dog. Dip. Door. What sound do you hear at the beginning of each word? The sound is /d/. (Make sure you don't add "uh" to the end of the sound.)
- Look at what my mouth is doing as I say /d/. Now you try. What is your tongue doing when you say /d/? Put your hand on your throat as you say /d/. Is it a quiet or noisy sound? (noisy)
- (Hold up the letter d card. Choose the letter style that you prefer.) This is the letter d. When we see this card, we say "d spells /d/." Your turn. (Students: "d spells /d/.")

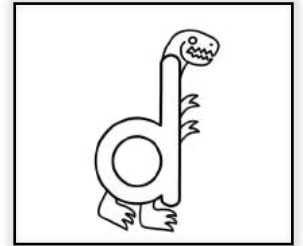

## FINGER-WRITE THE LETTER

- To make the letter d, we start in the middle, pull back, around, go all the way up, and down.
- Watch me put my hand in the air and write a d in the sky. I start in the middle, pull back, around, go all the way up, and down. Now you try. Put your finger in the air. Start in the middle, pull back, around, go all the way up, and down.
- Make a d by moving your finger on the table. Start in the middle, pull back, around, go all the way up, and down. (Other options: sand or salt tray, shaving cream, etc.) Now do the same thing while saying "d spells /d/." Remember to underline the d when you say /d/. (Practice multiple times.)

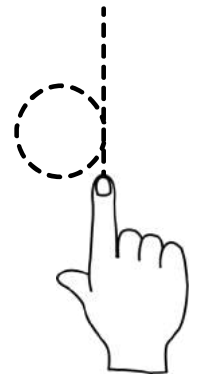

## ROLL & NAME THE LETTERS

**Printable: Roll & Name the Letters for each individual or pair of students**

- This game will give you practice naming the letters you've learned.
- Roll the die and find the row with that number in the front of it. Then read the letters in the row. Keep rolling and naming letters until I tell you to stop.

## READ ALOUD

**One Duck Stuck**, by Phyllis Root

- **Before reading:**
  - This book is a duck who gets stuck in muck. What is muck?
  - In this book, different animals try to help Duck get unstuck. What kind of animals do you think we'll read about in the book?
- **After reading:**
  - What problem does Duck have in this book?
  - What kinds of animals try to help Duck get unstuck?
  - How does the story end?

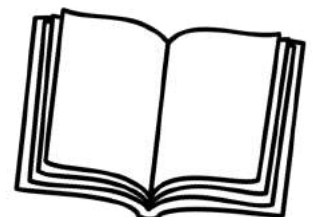
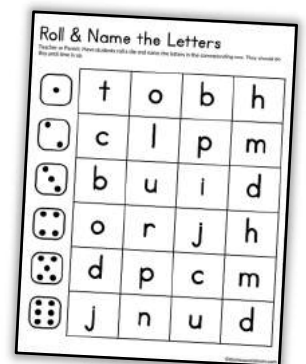

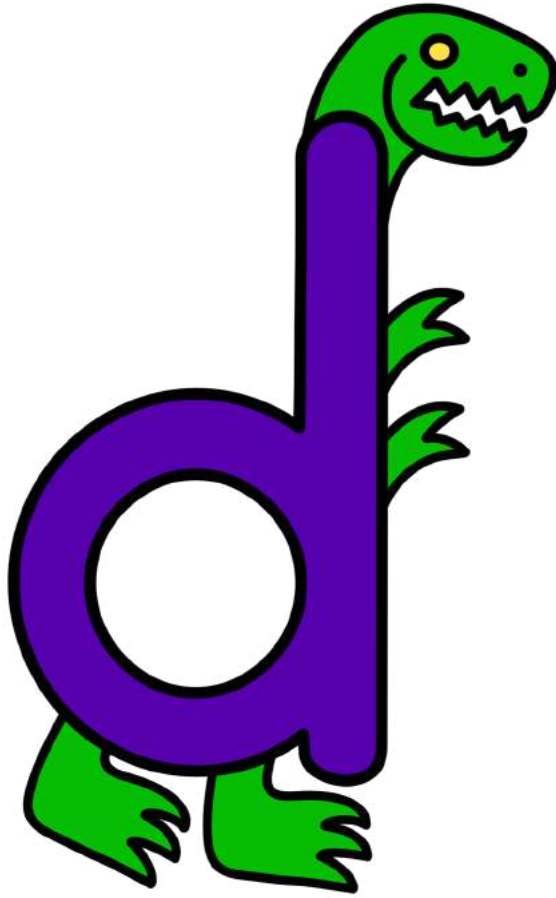

©themedasuredmom.com

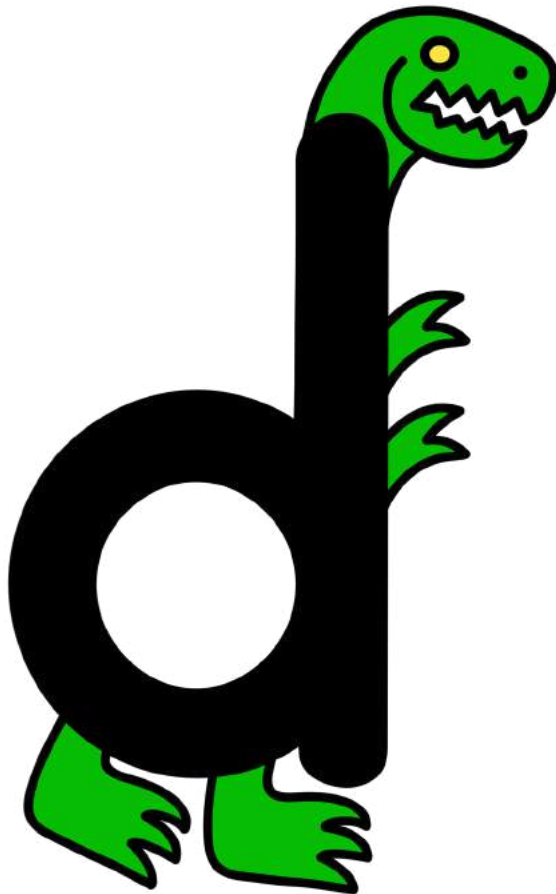

©themedasuredmom.com

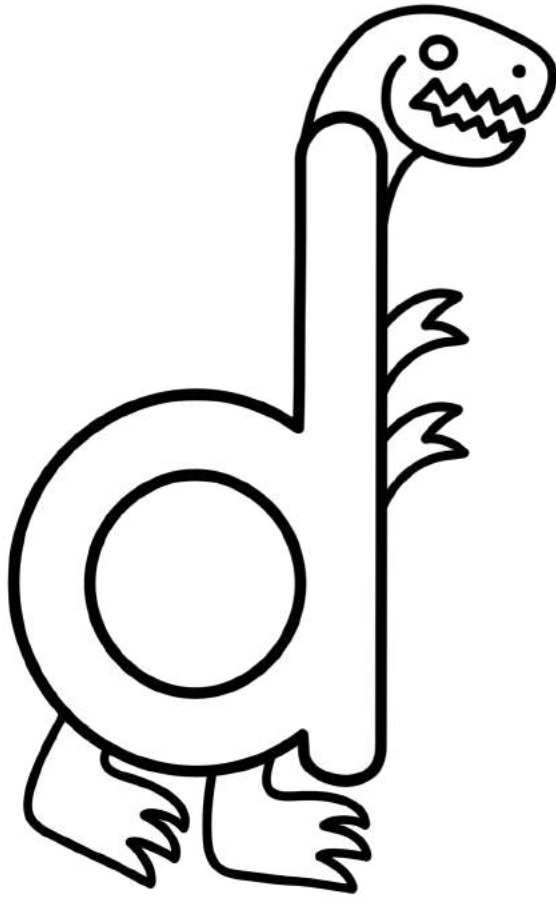

©themeasuredmom.com

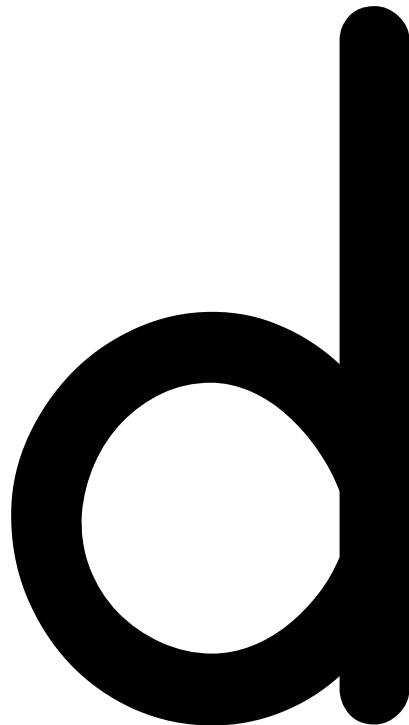

©themeasuredmom.com

# Roll & Name the Letters

Teacher or Parent: Have students roll a die and name the letters in the corresponding row. They should do this until time is up.



t

o

b

h



c

l

p

m



b

u

i

d



o

r

j

h



d

p

c

m



j

n

u

d



# Letter d – Day 2

## REVIEW THE LETTER AND SOUND

**Printable: Letter d Card (choose the format you prefer)**

- (Hold up the letter d card.) Remember that when I show you this card, you say “d spells /d/.” Now you say it.
- Watch me write a d in the air. Now it's your turn. Write three d's in the air. Start in the middle, pull back, around, go all the way up, and down.

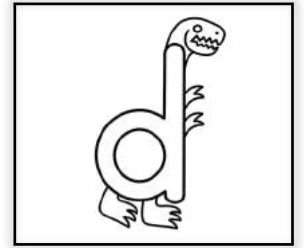

## HANDWRITING PRACTICE

**Printable: Letter d Tracing**

- I'm going to give you a piece of paper to practice writing d. Start by tracing it at the top of the paper with your finger. Say /d/ as you trace.
- Next, use your pencil to trace inside the shaded letter, trace inside the bubble letter, and trace the dotted letter.

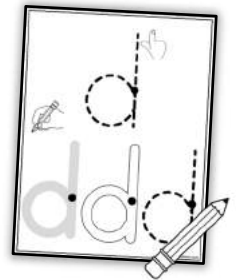

## PHONEME-GRAPHEME MAPPING

**Printable: Set of Boxes and Letters for each student (If desired, use magnetic letters or plastic tiles for the following: d, p, i, n, h.)**

- We are going to break a word into its sounds. Then we're going to use letters to spell the word!
- I have a set of three boxes and a set of counters. I am putting the counters at the top of the page in the circle. Watch me separate a word into its sounds and move a counter into a box as I say each sound. The word is DIP. The sounds are /d/ /i/ /p/. (Put a counter in a box as you say each sound.)
- Watch me check my sounds as I point to the counters. /d/ /i/ /p/.
- Now I'm going to spell DIP! The first sound in DIP is /d/. The letter d spells /d/, so I will move it into the first box as I push out the counter. The next sound is /i/. The letter i spells /i/, so I am going to push out the counter and move the letter i into the second box. The final sound is /p/. P spells /p/, so I'll move a p into the last box. Now I'll slide my finger under the letters and read the word. DIP.
- Now it's your turn to spell with me! (Do the above procedure with your students for the following words: NIP, HIP, HID.)

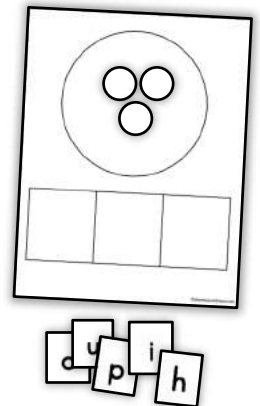

## VOCABULARY RIDDLES

- I have some riddles for you to solve. Listen to my clues. Say the sound /d/ quietly to yourself as you work to figure out the answer. Raise your hand when you know the answer to my riddle. When everyone has raised their hand, I will stop giving clues and call on one of you for the answer.
  - This is something that comes in different flavors.
  - It is often a kind of breakfast treat.
  - Sometimes it has sprinkles on top.
  - It is round and sweet and often has a hole in the middle. (DONUT)
  - These people are community helpers who are important for people's health.
  - They are a kind of doctor who works on a person's mouth.
  - They examine your teeth and can help if you have a cavity. (DENTISTS)



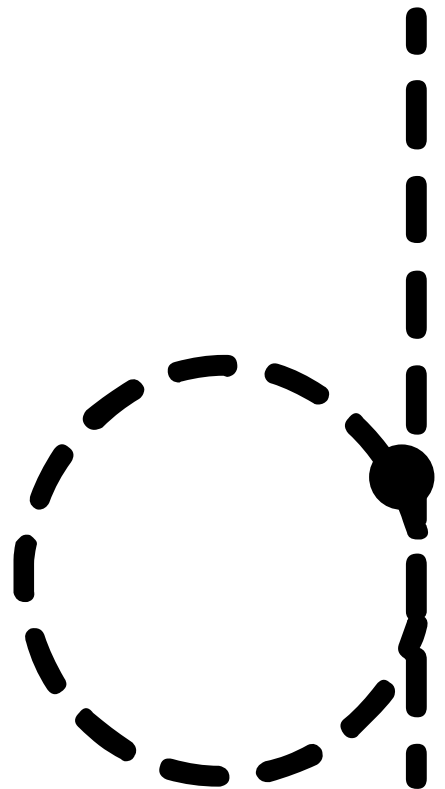
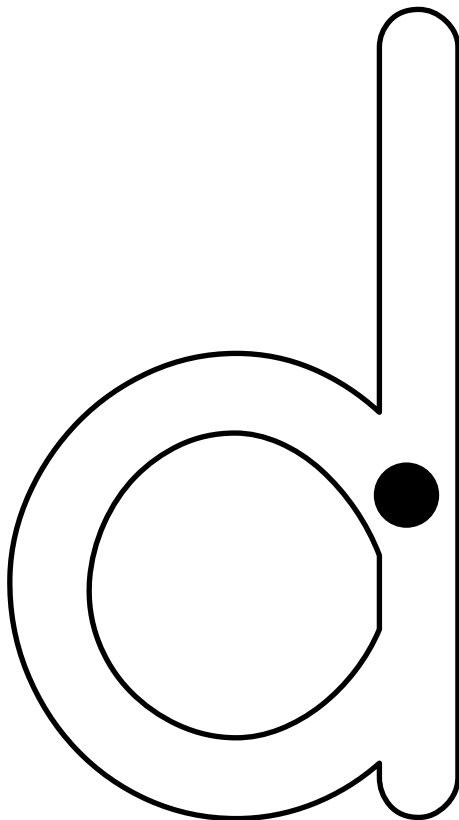
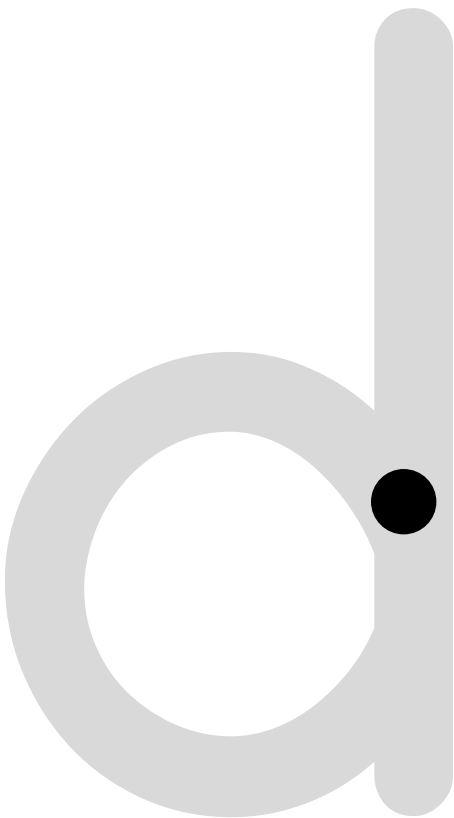
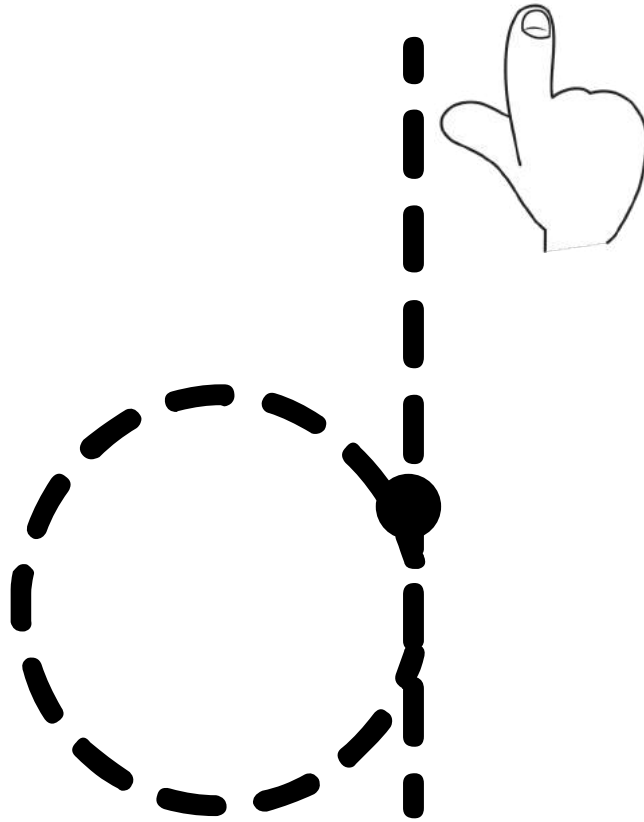
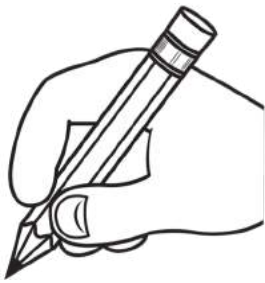

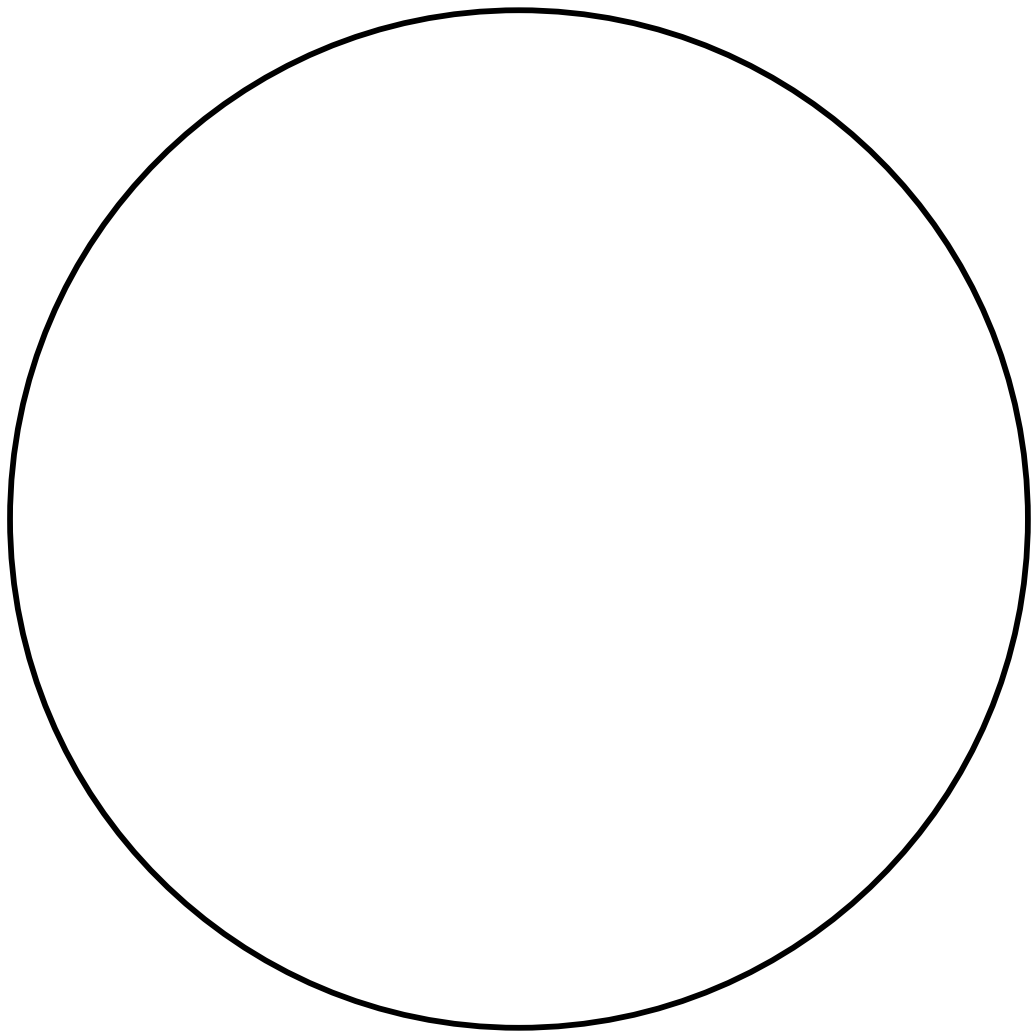

--	--	--

Cut out a row of letter tiles for each student, or use magnetic letters or other letter manipulatives: d, p, i, n, h.

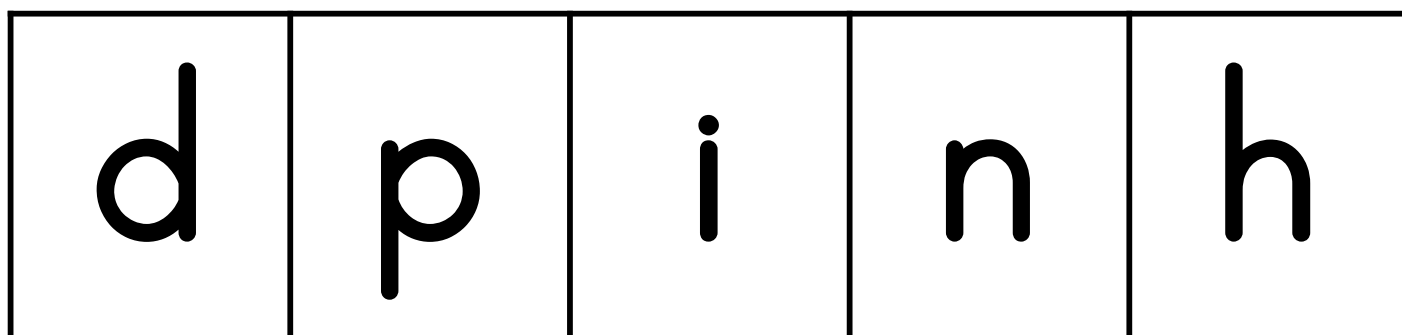
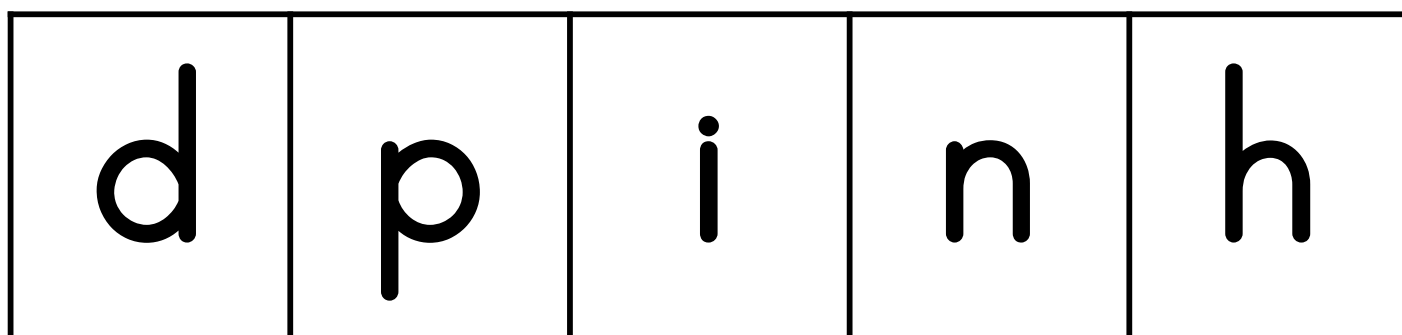
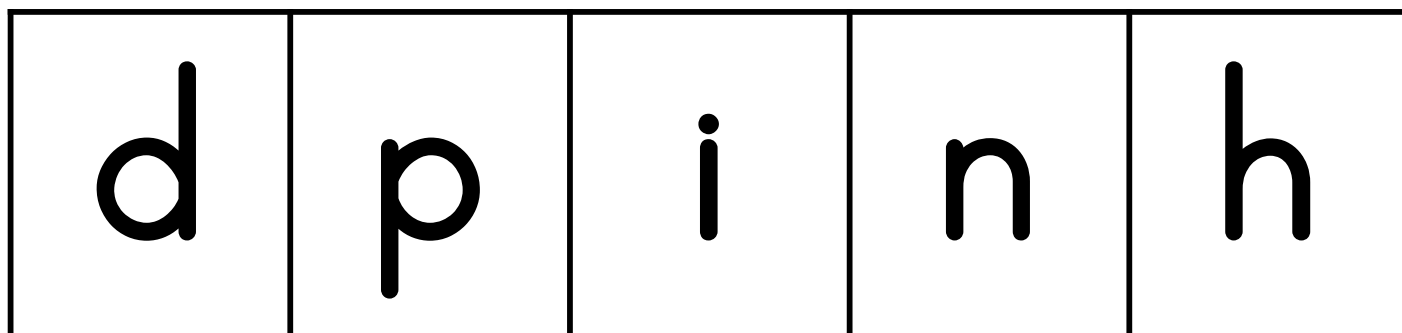
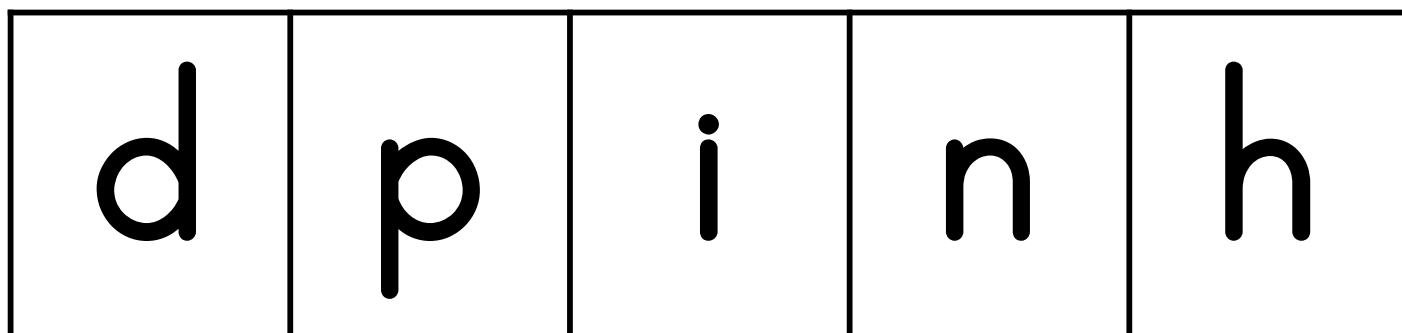
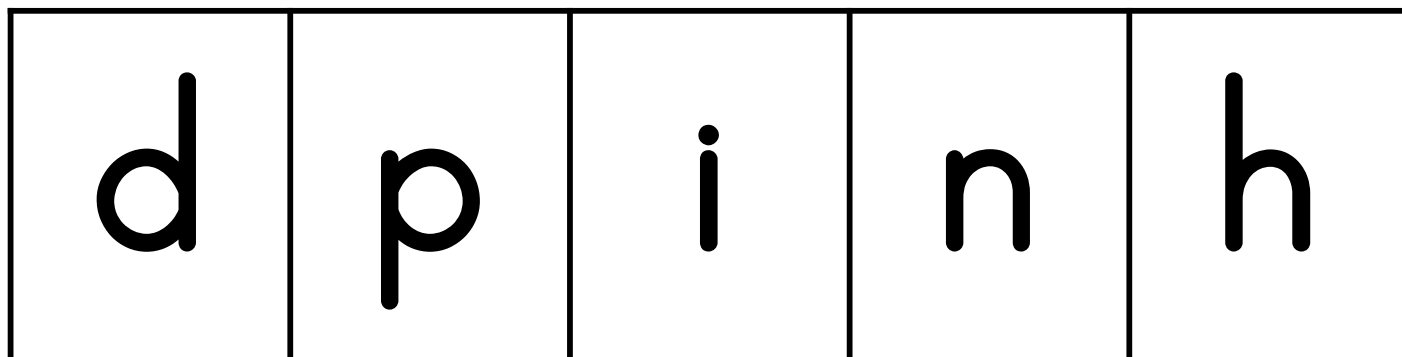

# Letter d – Day 3

## REVIEW PREVIOUSLY LEARNED LETTERS AND SOUNDS

**Printable: Letter t, l, i, j, u, r, n, m, h, b, p, o, c, and d Cards**

- I'm going to mix up the cards so you can practice saying the letters with their sounds. When I show you a letter, say its name and sound while writing it with your finger on the table. Watch me. "D spells /d/." (Finger-write the letter while saying "d." While saying /d/, underline the letter with your finger.)

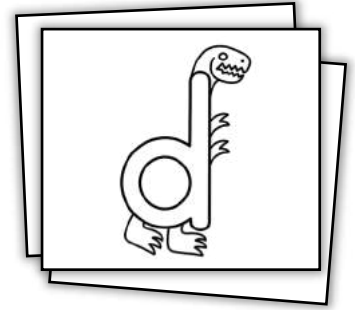

## WRITE THE LETTER

**Printable: Write the Letter d Handwriting Page**

- We are going to practice writing the letter d on paper. Finger-trace the letter at the top. Trace the next row. For the last line, write three d's, starting at the dot. Circle your best d. (Help students identify the pictures at the bottom of the page, isolate the beginning sounds, and determine which pictures' names begin with /d/.)

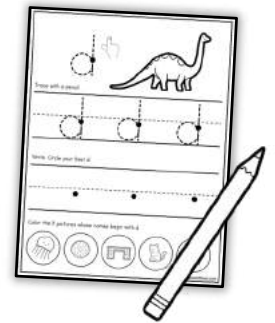

## POCKET CHART SYLLABLE SORT

**Printable: Pocket Chart Syllable Sort**

- (Cut out the pocket chart cards. Put the number cards at the top of a pocket chart as headers.)
- Today we are going to sort words depending on how many syllables are in their names. You can see that I have the numbers 1, 2, and 3 on our pocket chart. Each of these words has 1, 2, or 3 syllables.
- The first word is DONUT. I can clap it like this: DO-NUT. Since DONUT has two syllables, I put it under the 2.
- Let's do the rest of these cards together.

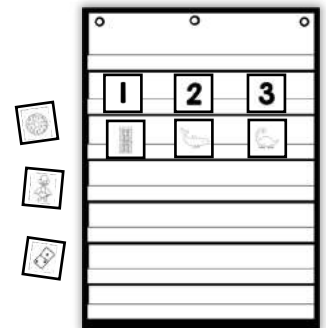

## LETTER SOUND CUT & PASTE

**Printable: Letter Sound Cut & Paste: d**

- Cut out the pictures and name them. Be sure to say the beginning sound of each picture, like this. Duck. /d/ /d/ duck. Then glue it onto the block letter. (Help with cutting if necessary.)
- (Work with your students as they complete the activity.)

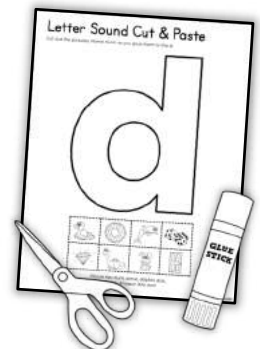

## LITTLE LETTER BOOK

**Printables: Little Letter Dd Book & My Dd Book**

(Print and assemble a copy of either the Little Letter Dd Book, My Dd Book, or both for each of your students. Read the book(s) to your learners. Make sure they have a place to store their little books so they can enjoy them at a future date.)

**Printing instructions:** Print the book of your choice front to back. Then cut across the horizontal center of the pages, fold and fit the pages together, and open back up to staple with a long-arm stapler. When you are done, you will have a little book.

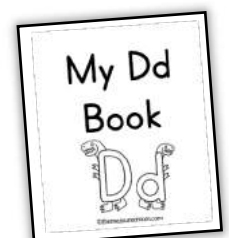

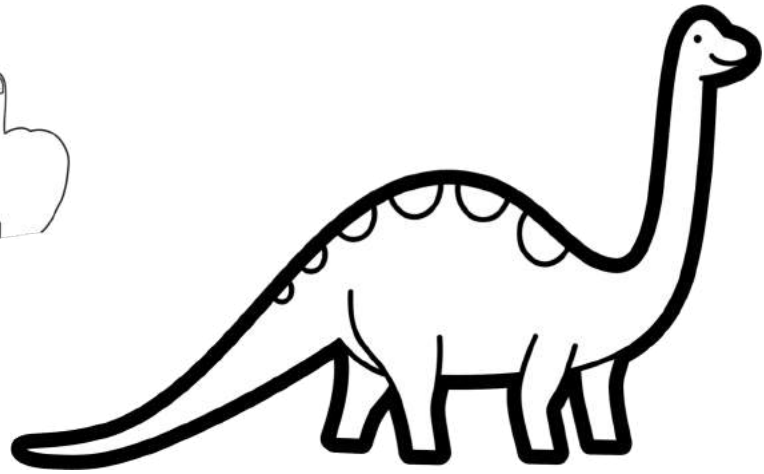
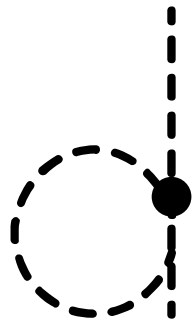

Trace with a pencil.

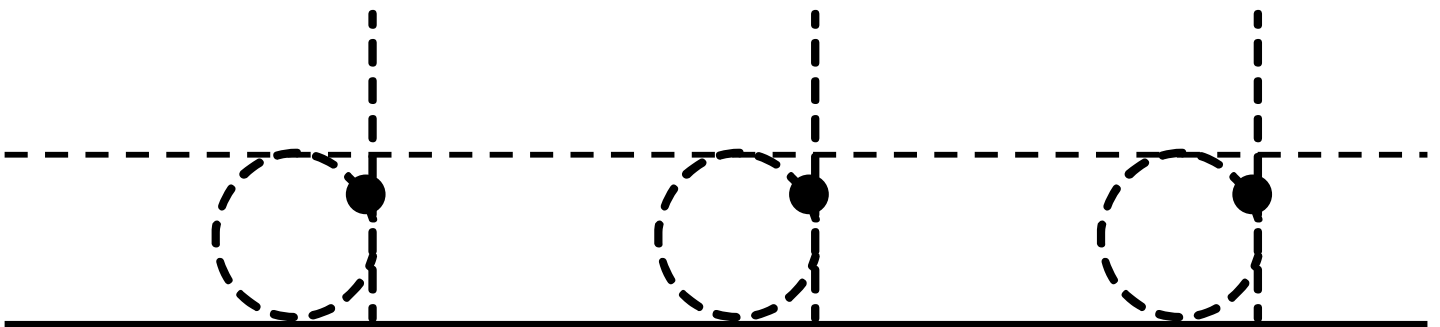

Write. Circle your best d.

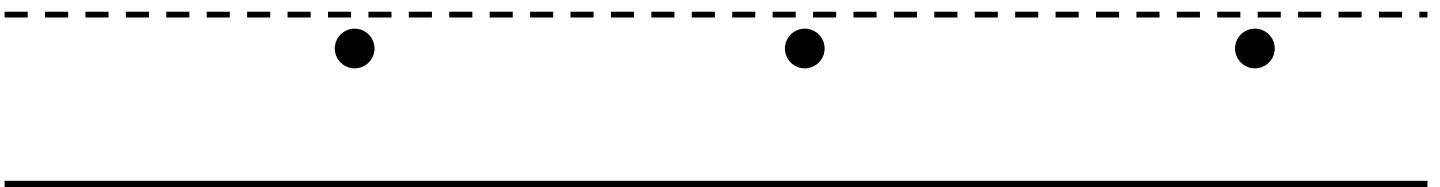

Color the 3 pictures whose names begin with d.

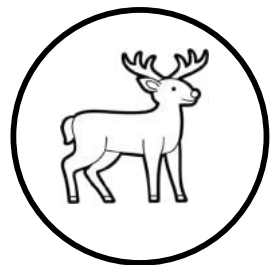
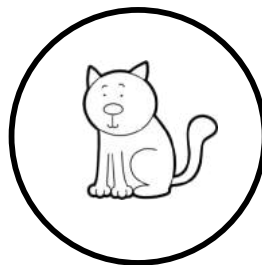
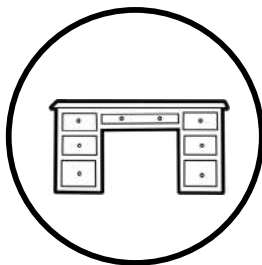
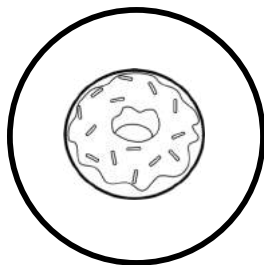
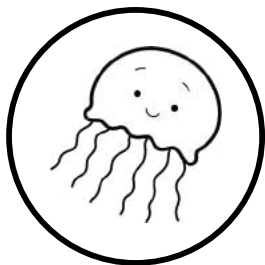

1

2

3

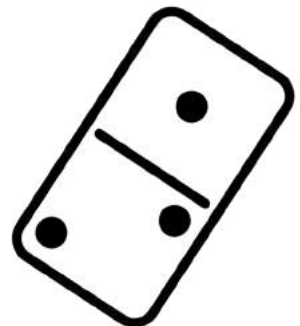
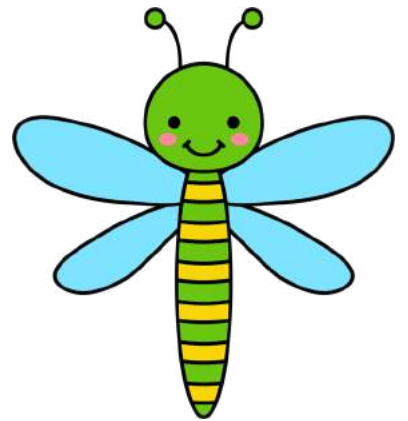
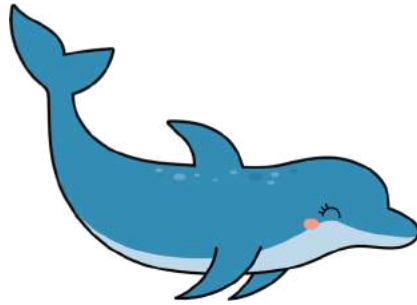
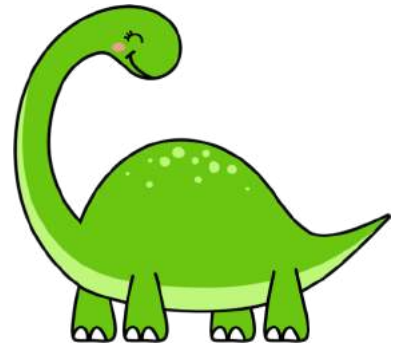
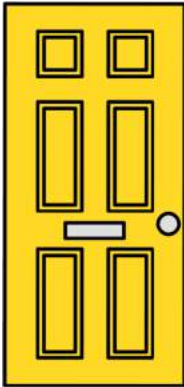

1

2

3

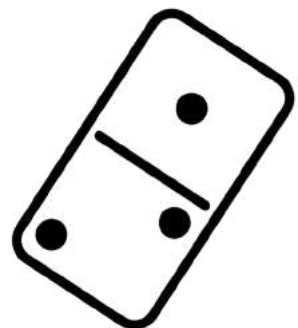
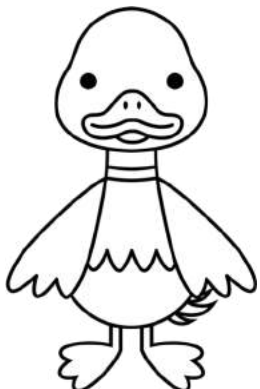
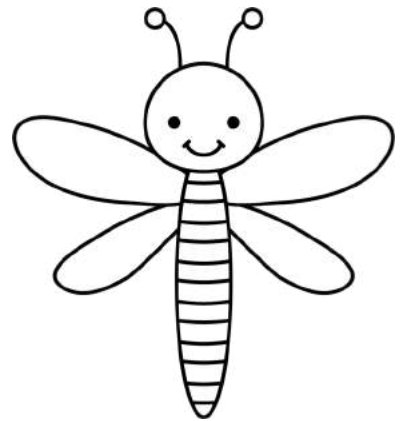
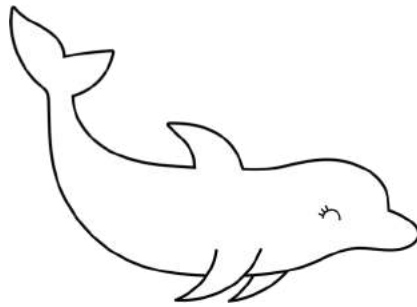
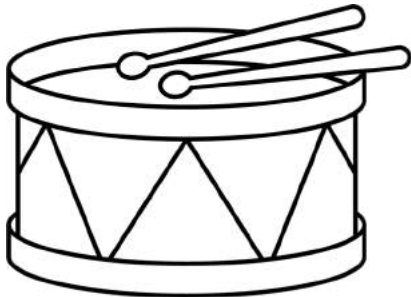
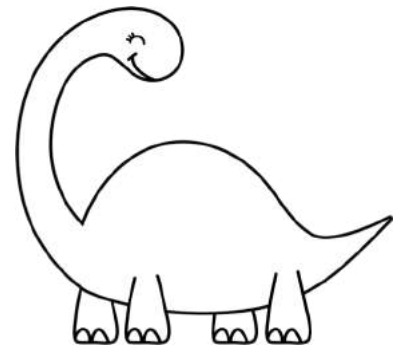
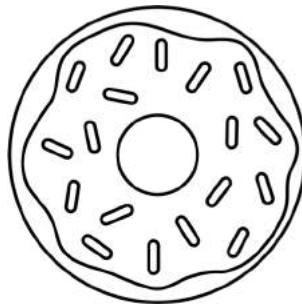
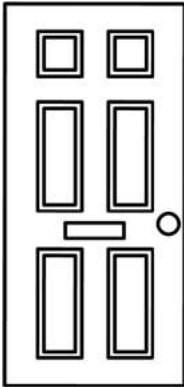



# Letter Sound Cut & Paste

Cut out the pictures. Name them as you glue them to the d.

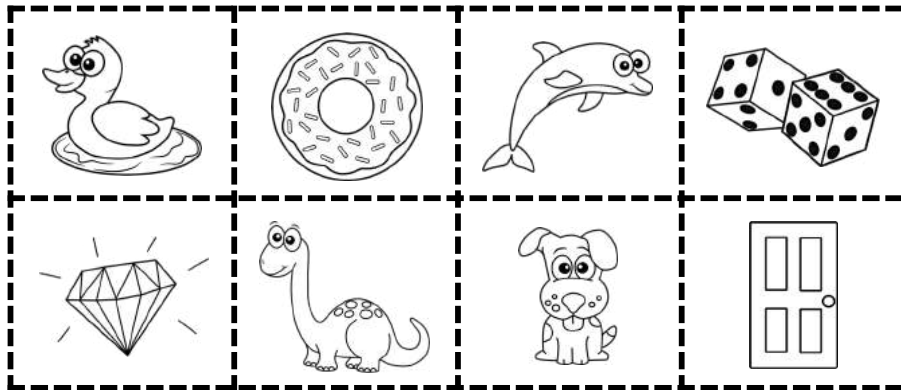
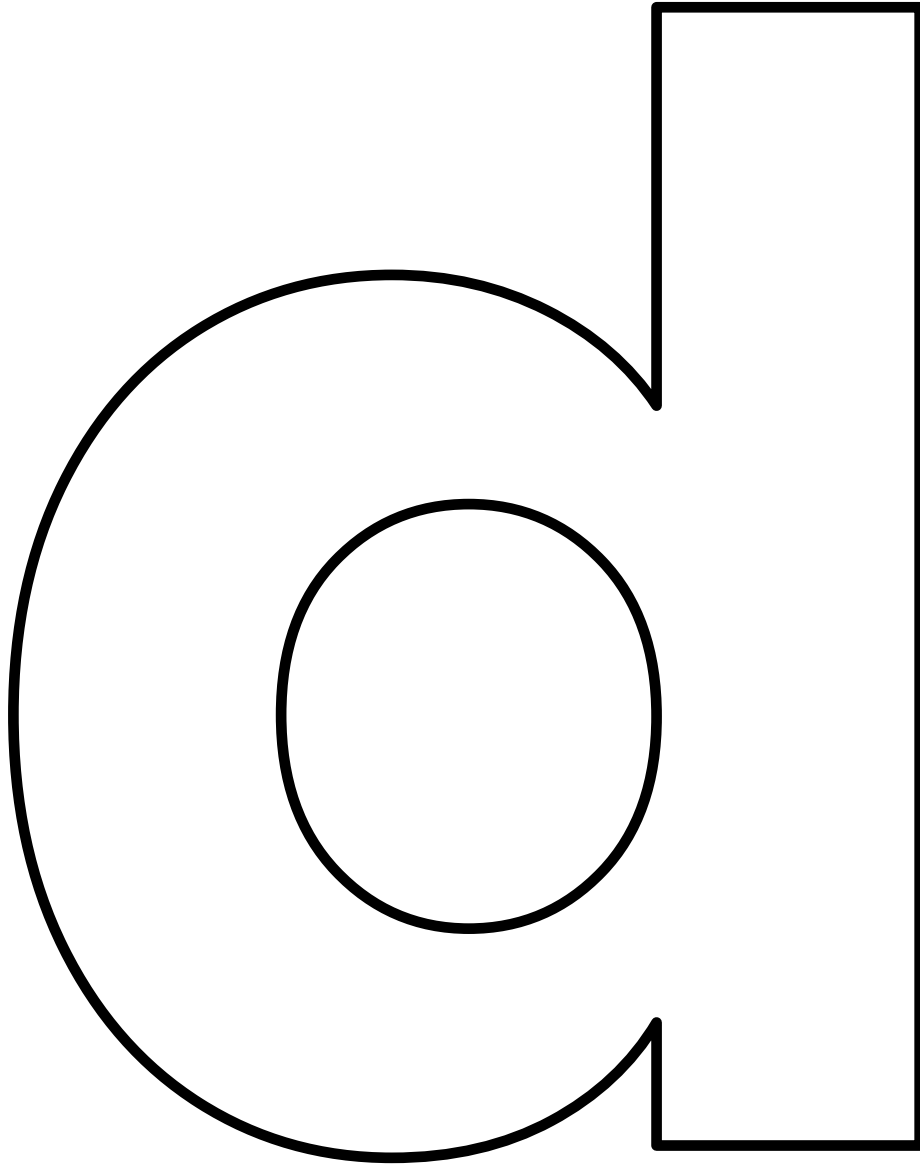

Picture Key: duck, donut, dolphin, dice,  
diamond, dinosaur, dog, door

# Diddle Diddle Dumpling



Diddle diddle dumpling, my son John  
Went to bed with his trousers on.  
One shoe off and one shoe on,  
Diddle diddle dumpling, my son John.

# The Days of the Week

(Tune: Oh My Darling, Clementine)



Sunday, Monday, Tuesday, Wednesday,  
Thursday, Friday, Saturday.  
Sunday, Monday, Tuesday, Wednesday,  
Thursday, Friday, Saturday.

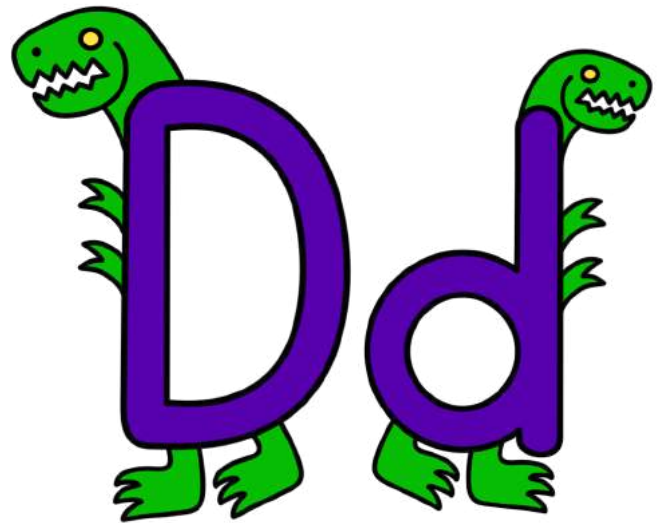
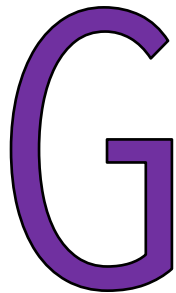
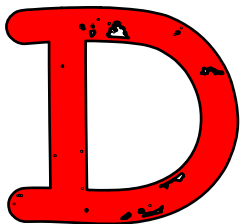
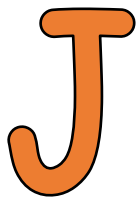
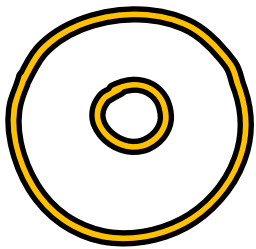

Can you find the D?

Little Letter Dd Book

## Donkey, Donkey, Old and Gray

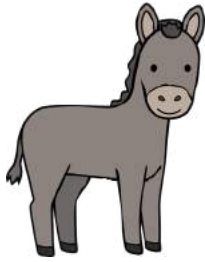

Donkey, donkey,  
Old and gray.  
Open your mouth  
And gently bray.

Lift your ears  
And blow your horn  
To wake up the world  
This sleepy morn.

## Down by the Station



Down by the station,  
Early in the morning.  
See the little puffer bellies  
All in a row.  
See the engine driver  
Pull the little throttle.  
Puff puff, toot, toot, off we go!

## Diddley, Diddley, Dumpty



Diddley, diddley, dumpty.  
The cat ran up the plum tree.  
Give her a plum, and down she'll come.  
Diddley, diddley, dumpty.

## Dr. Foster Went to Gloucester



Doctor Foster  
Went to Gloucester  
In a shower of rain.  
He stepped in a puddle  
Right up to his middle  
And never went there again!

# Diddle Diddle Dumpling



Diddle diddle dumpling, my son John  
Went to bed with his trousers on.  
One shoe off and one shoe on,  
Diddle diddle dumpling, my son John.

# The Days of the Week

(Tune: Oh My Darling, Clementine)

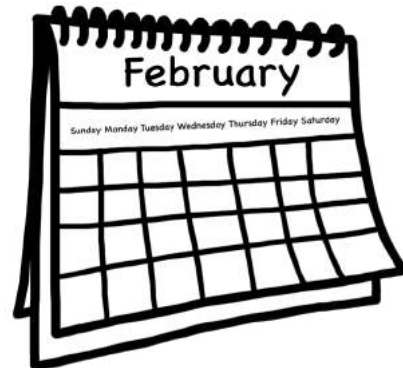

Sunday, Monday, Tuesday, Wednesday,  
Thursday, Friday, Saturday.  
Sunday, Monday, Tuesday, Wednesday,  
Thursday, Friday, Saturday.

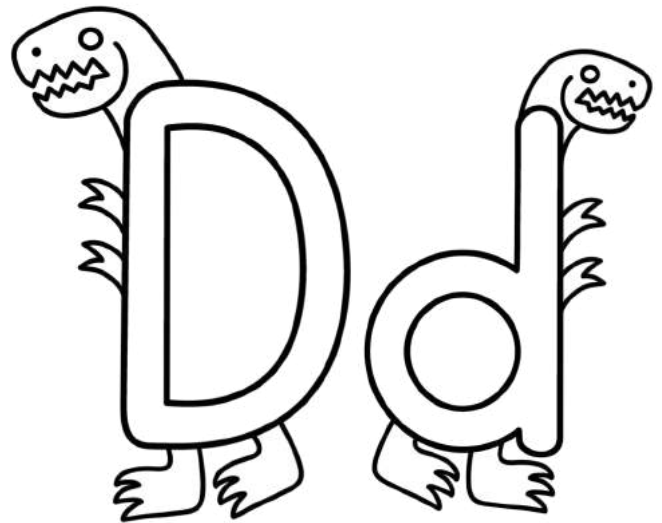
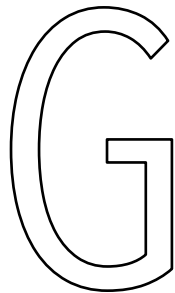
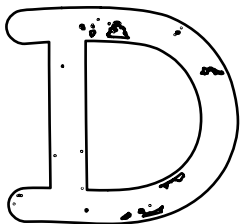
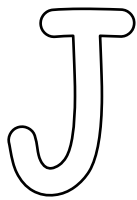
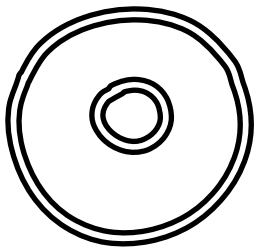

Can you find the D?

Little Letter Dd Book

## Donkey, Donkey, Old and Gray

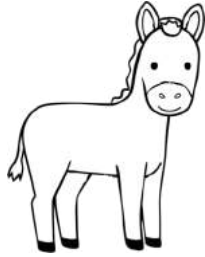

Donkey, donkey,  
Old and gray.  
Open your mouth  
And gently bray.

Lift your ears  
And blow your horn  
To wake up the world  
This sleepy morn.

## Down by the Station

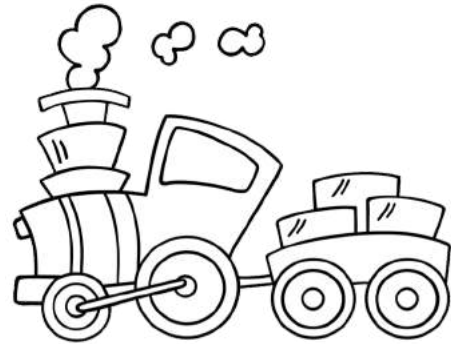

Down by the station,  
Early in the morning.  
See the little puffer bellies  
All in a row.  
See the engine driver  
Pull the little throttle.  
Puff puff, toot, toot, off we go!

## Diddley, Diddley, Dumpty

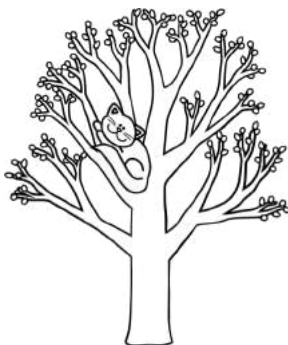

Diddley, diddley, dumpty.  
The cat ran up the plum tree.  
Give her a plum, and down she'll come.  
Diddley, diddley, dumpty.

## Dr. Foster Went to Gloucester



Doctor Foster  
Went to Gloucester  
In a shower of rain.  
He stepped in a puddle  
Right up to his middle  
And never went there again!

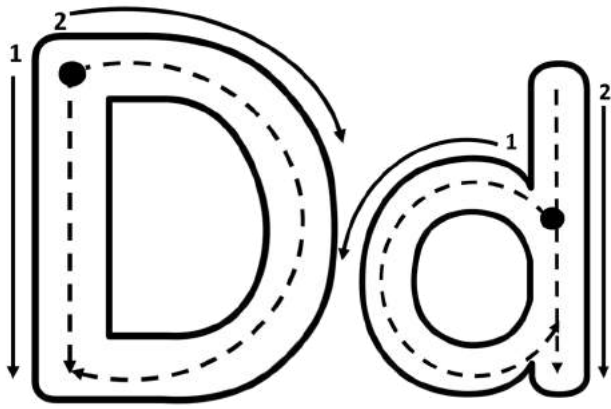

Trace it!

# My Dd Book



©themeasuredmom.com



dice

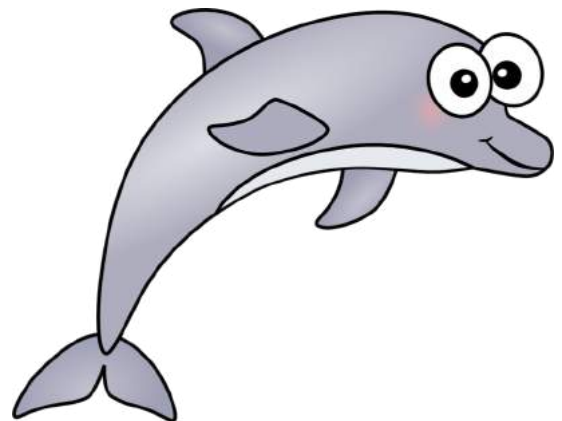

dolphin



duck

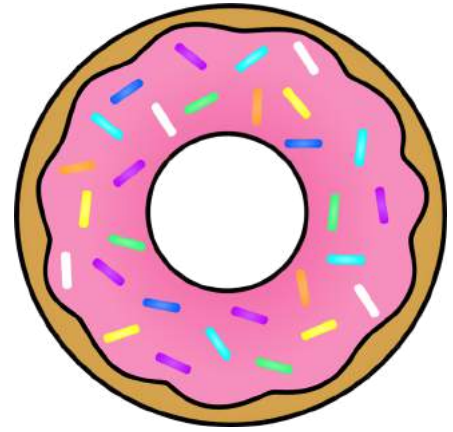

donut

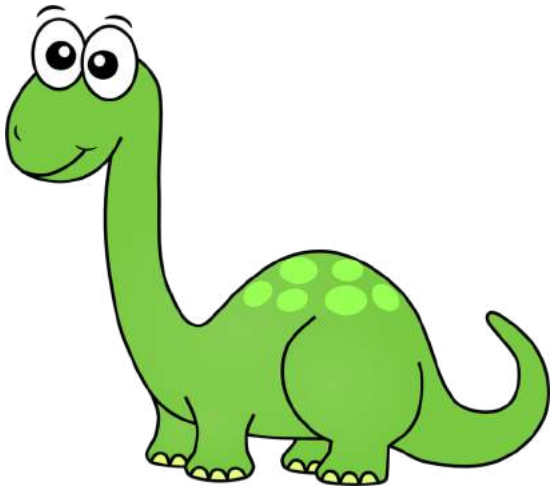

dinosaur



dog

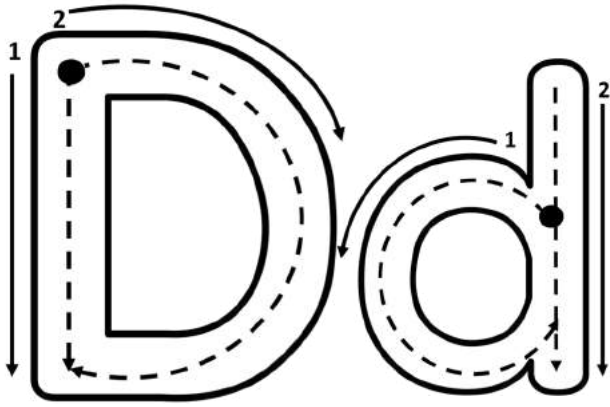

Trace it!

# My Dd Book

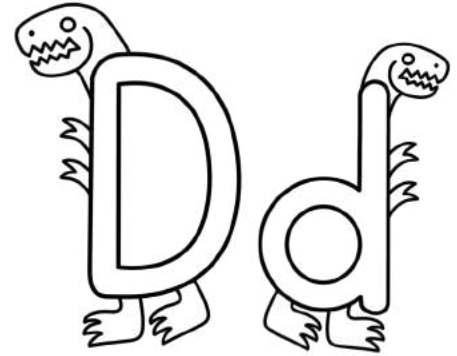

©themeasuredmom.com

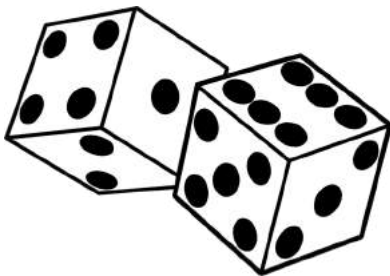

dice

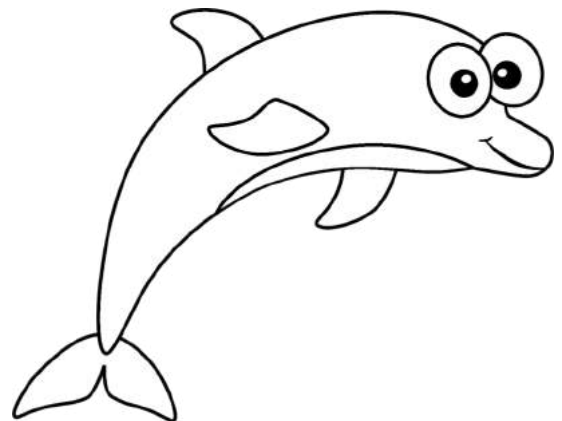

dolphin





duck

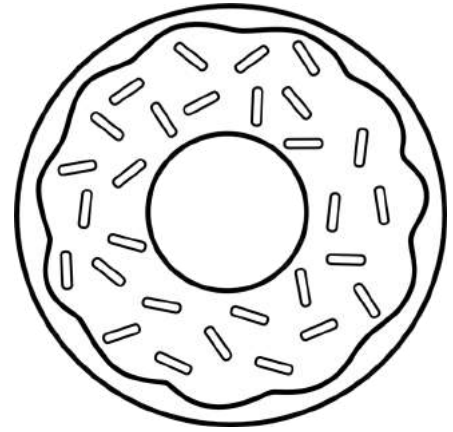

donut

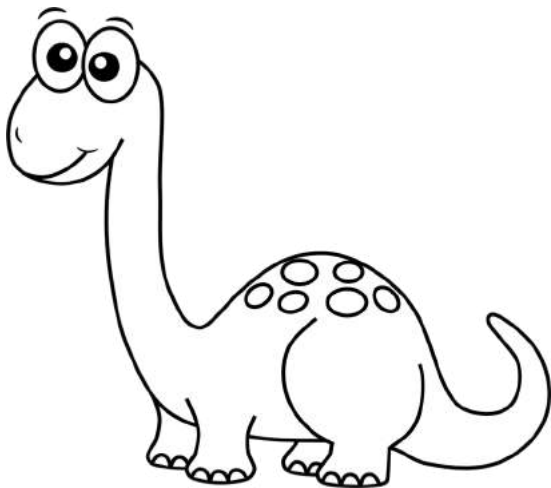

dinosaur



dog

# Letter Dd Book List

---

- ***All Aboard the Dinotrain***, by Deb Lund
- ***Arnie the Doughnut***, by Laurie Keller
- ***Be Gentle with the Dog, Dear!*** by Matthew Baek
- ***The Complete Adventures of Big Dog and Little Dog***, by Dav Pilkey
- ***Dinorella***, by Pamela Duncan Edwards
- ***Doctor De Soto***, by William Steig
- ***Dog Loves Drawing***, by Louise Yates
- ***The Doorbell Rang***, by Pat Hutchins
- ***Doris's Dinosaur***, by Rosemary Wells
- ***The Dot***, by Peter Reynolds
- ***Duncan & Dolores***, by Barbara Samuels
- ***A Friend for Dragon***, by Dav Pilkey
- ***Go, Dog. Go!*** by P.D. Eastman
- ***Goldilocks and the Three Dinosaurs***, by Mo Willems
- ***Hand, Hand, Fingers, Thumb***, by Al Perkins
- ***The Happy Man and His Dump Truck***, by Miryam
- ***How Do Dinosaurs Love Their Dogs?*** by Jane Yolen
- ***How Droofus the Dragon Lost His Head***, by Bill Peet
- ***One Duck Stuck***, by Phyllis Root
- ***There's NO Such Thing as a Dragon***, by Jack Kent
- ***When Dinosaurs Came with Everything***, by Elise Broach

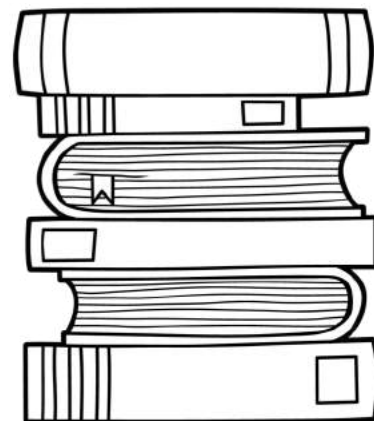

# Bonus: Crafts & Sensory Fun

---

It is unlikely that these activities will help your students master a letter's name or sound. However, they can be a fun exposure to letters while your learners build fine motor skills and exercise their creativity.

## **ALPHABET DETECTIVE**

Play alphabet detective. Write the alphabet on the chalkboard, dry erase board, or piece of paper. Leave some letters out. Tell your learners that some letters are missing, and you need their help to find them.

As you sing through the alphabet, stop at a missing letter. "Wait! What goes here?" Have your learners help you name the missing letters.

## **READ AND CREATE A DONUT CRAFT**

After reading *Arnie the Doughnut*, by Laurie Keller, or *If You Give a Dog a Donut*, by Laura Numeroff, make a simple donut craft. You'll need a paper plate, paint, glue, and something for sprinkles. Simply cut a hole in the center of a paper plate, paint, and let dry. Then use glue to attach "sprinkles" – they can be glitter, hole punch scraps, bits of tissue paper, etc.

## **DISAPPEARING LETTERS**

Write letters on a chalkboard with chalk. Then have your learners trace the letters with a paintbrush dipped in water to make them disappear. This is a sneaky way to get in some fine motor practice!

## **EYE DROPPER PAINTING**

Fill cups with a little bit of water and some food coloring. Then get a plastic eye dropper or pipette. Let your learners drop the colored water onto a paper towel.

## **DUPLO PAINTING**

Have your learners dip Duplo bricks into washable paint and make prints on paper. If you soak the Duplos in soapy water for a few minutes, the paint comes off easily.

## **LETTER FORMATION SENSORY MATERIALS**

Provide your learners with one or more of the following materials to form the letter d. You can have them fill the inside of a block letter or form the letter without a framework.

- Loose objects: mini donuts, toy dinosaurs, dandelion tops, dice, dimes, dog stickers, dots (using Do-a-Dot markers), Duplos
- Material to finger-write in: loose dirt

## **SNACKS**

- Healthy snack ideas: dates, dip
- Packaged snacks: donuts, Doritos
- Food to prepare together: dumplings

# Bonus: Math & Science

---

Looking for ways to build math and science skills? Consider any of these optional activities that go with letter Dd.

## **DINOSAUR EXCAVATION**

Freeze small toy dinosaurs inside balloons filled with water. When frozen, cut off the balloons. Give your child an eye dropper, pipette, turkey baster, etc. to melt the ice off the dinosaurs. Get a full tutorial at Little Bins for Little Hands. <http://bit.ly/1IRMkzt>

## **DENSITY EXPERIMENT**

Do a simple sink/float density experiment using a bowl of water and small objects around the house. Learn more at Inspiration Laboratories. <http://bit.ly/1AIZij>

## **DUMP TRUCK COUNTING**

Get different sizes of toy dump trucks. How many of a particular object can fit in the back? How many blocks? How many potatoes? etc. Have students make predictions and check their predictions. Help them count the objects.

# Bonus Printables

---

Use any of these printables for additional practice, or feel free to skip them!

\*Click on the name of a printable to jump right to it!

- **Letter d Find**
- **Block Letter d**
- **Road Tracing Letter Formation**
- **Letter Dd Flip Book**
- **Name it & Dot it**
- **Play Dough Mat: Letter Dd**
- **Does it Begin with d?**
- **Trace, Write, Color, and Dot Worksheet**
- **Trace It! Letter d**
- **Letter Dd Trace & Color Worksheet**
- **Letter Dd Sort with Different Fonts**
- **Letter d Sound Cover**

# Letter d Find

This page has many different letters on it, but your job is to find the d's. Color or cover the d's on the page. As you find them, say /d/.



d	j	d	s	d
w	d	k	n	d
m	l	d	d	b
z	d	d	v	e
d	t	p	i	d
h	d	d	d	a

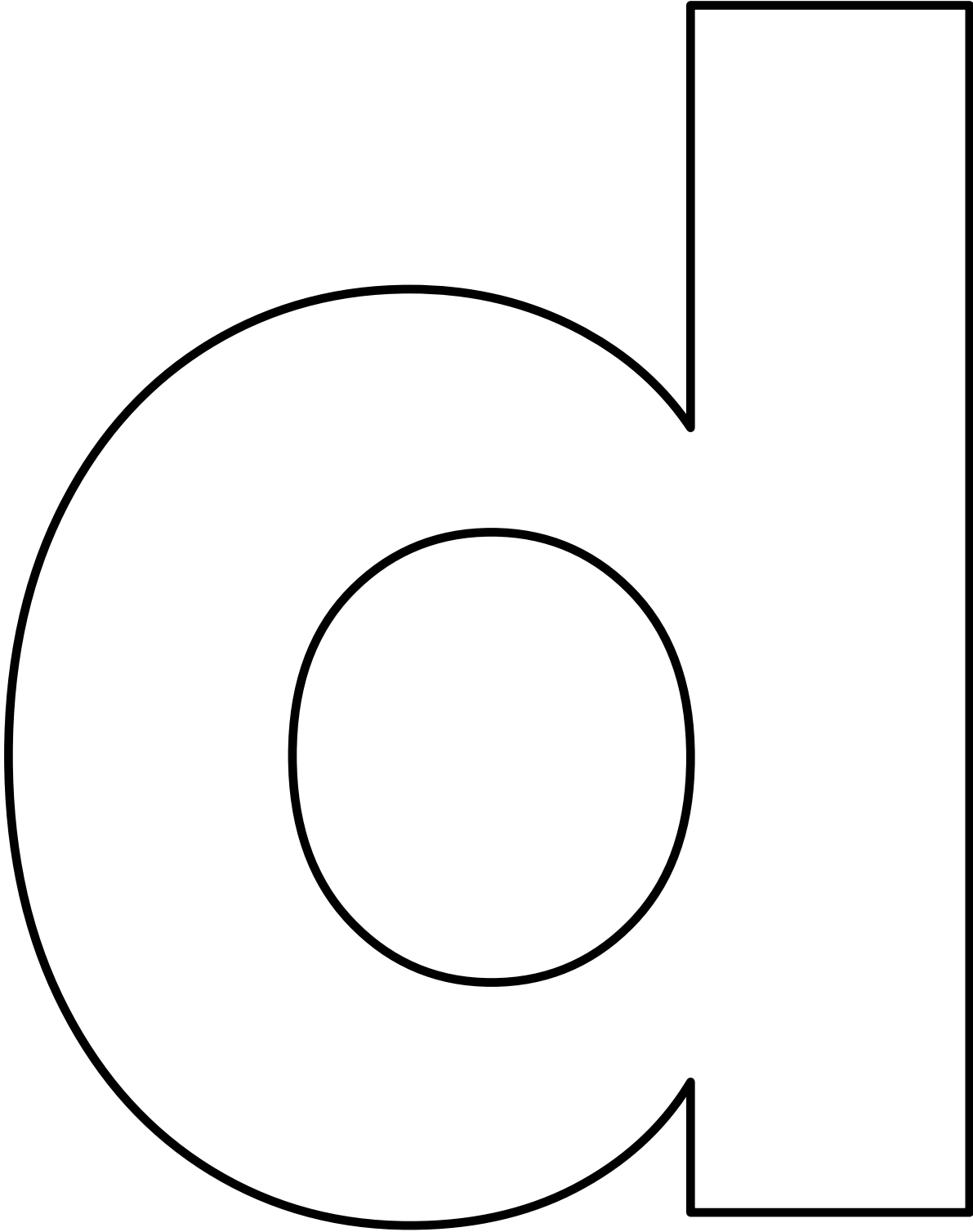

Drive.

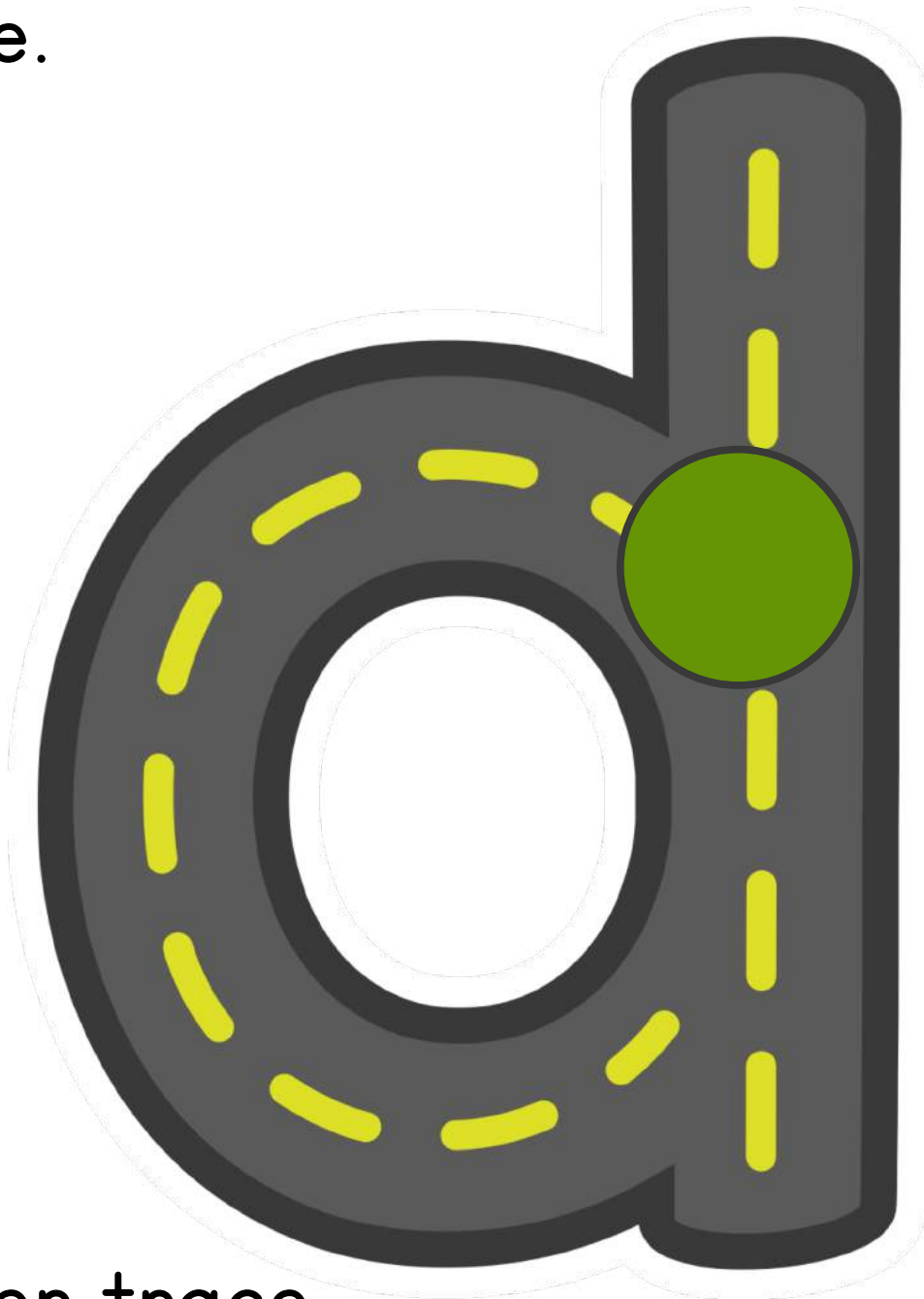

Finger trace.

©themeasuredmom.com

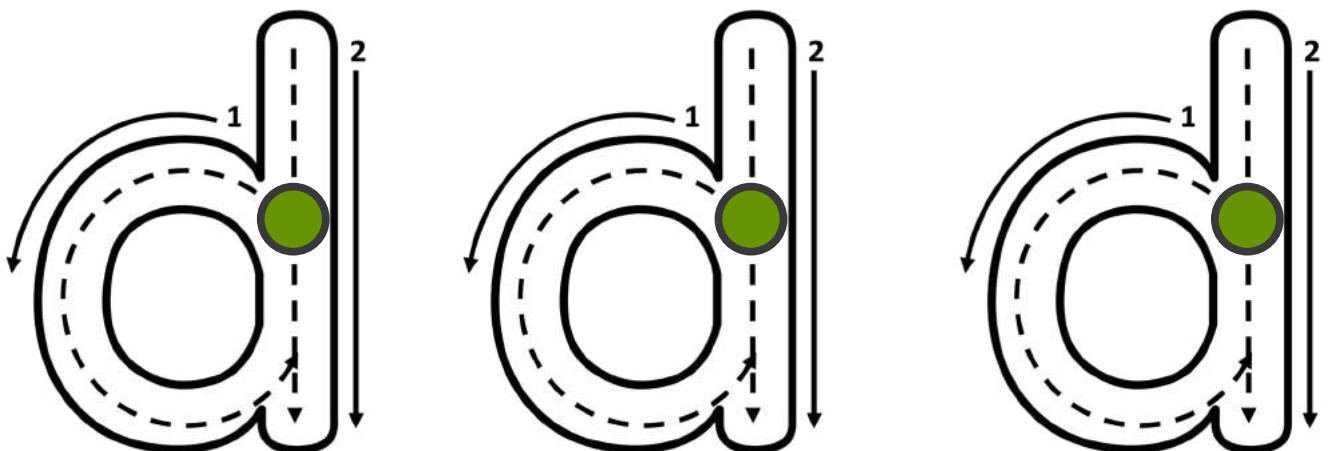



Drive.

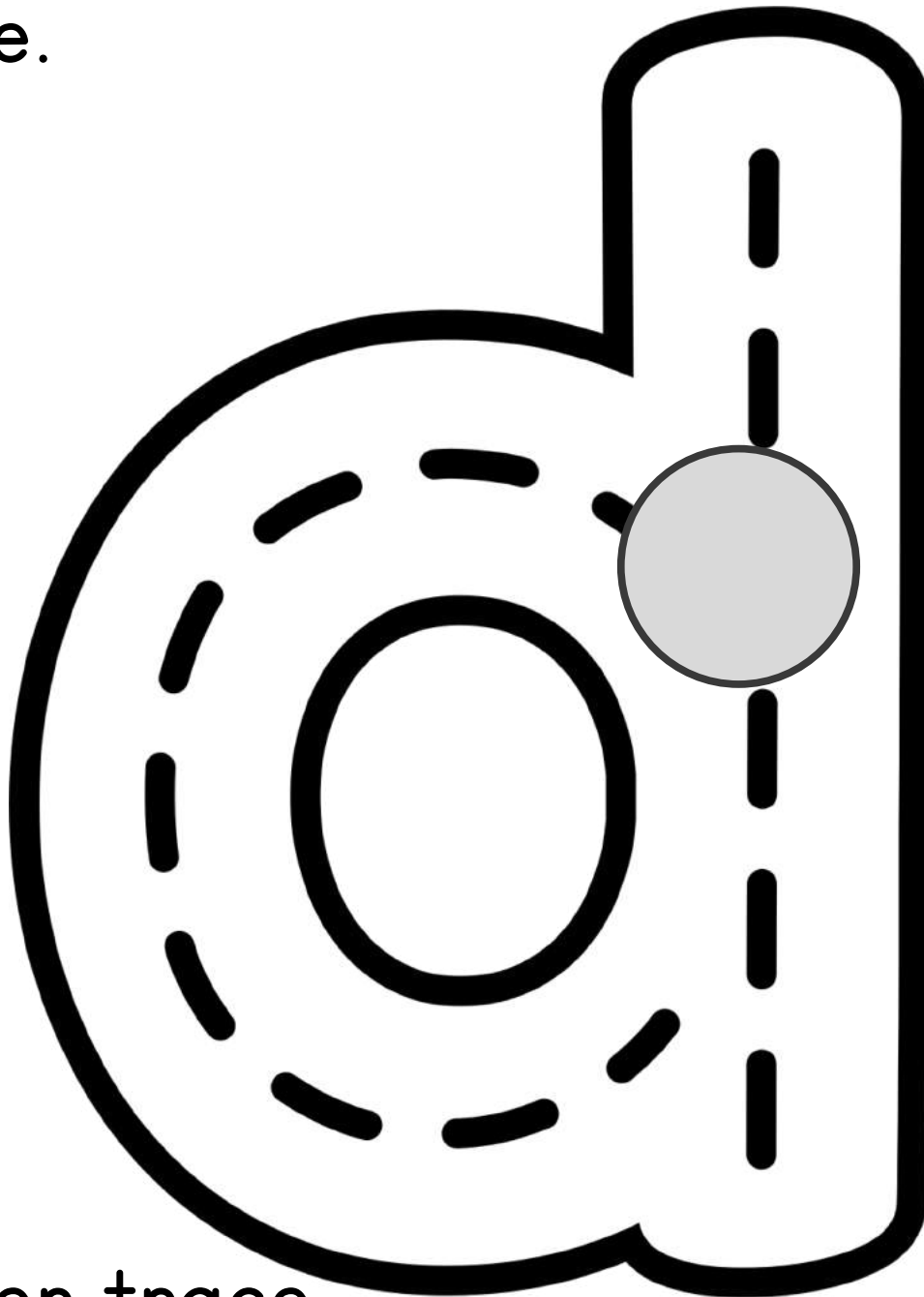

Finger trace.

©themeasuredmom.com

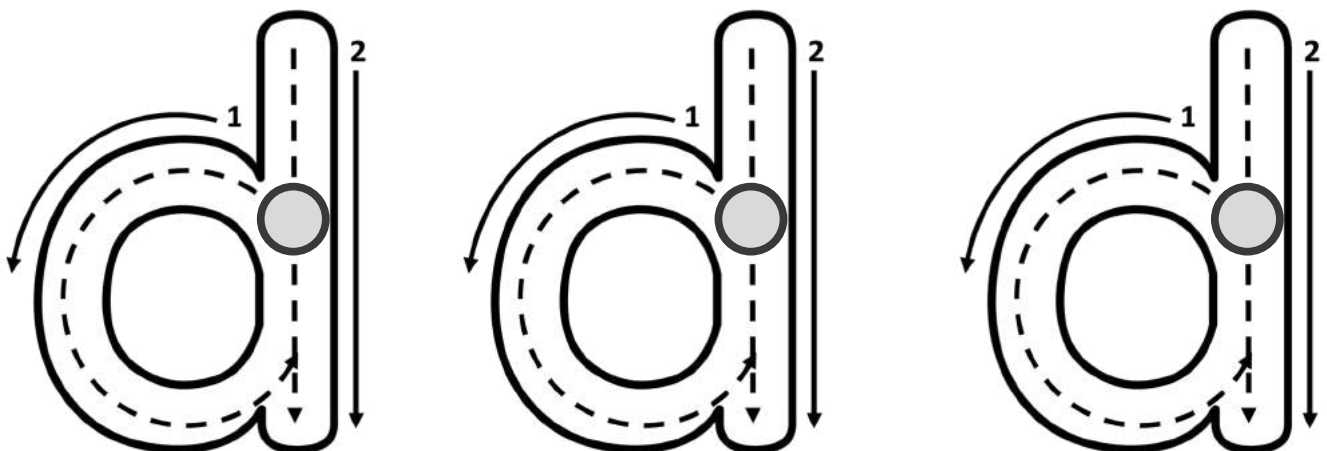

# Letter Dd Flip Book

**Dd is for**

**doctor**

GLUE

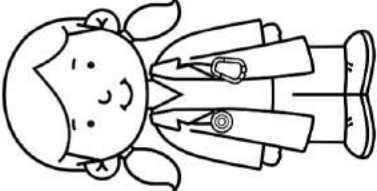

©thameasureedmom.com

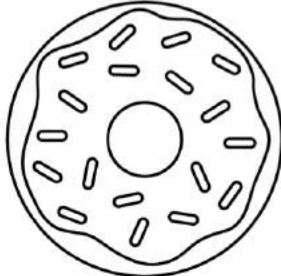
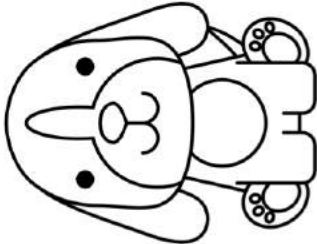
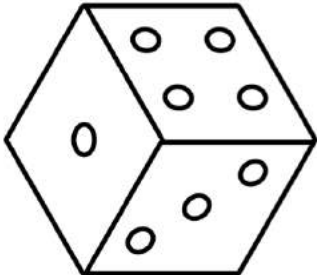
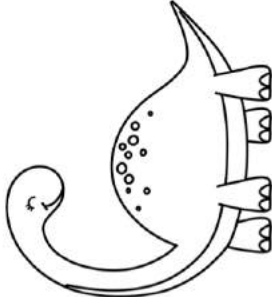
GLUE		donut
GLUE		dog
GLUE		dice
GLUE		dinosaur

Cut out the large rectangle on the left and the little rectangles on the right. Glue each image on top of the doctor until the donut is on top. Your students can “read” the flip book.

# Name it & Dot it

Use dot markers to stamp  
the letters and pictures.

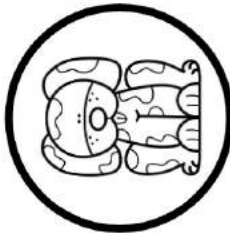
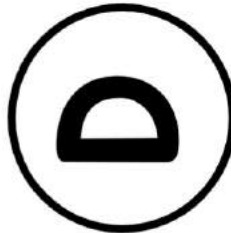
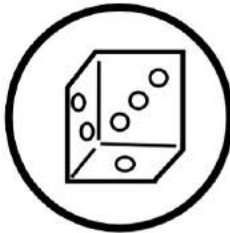
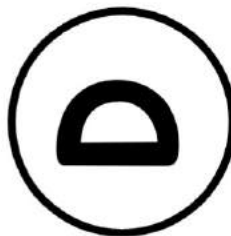
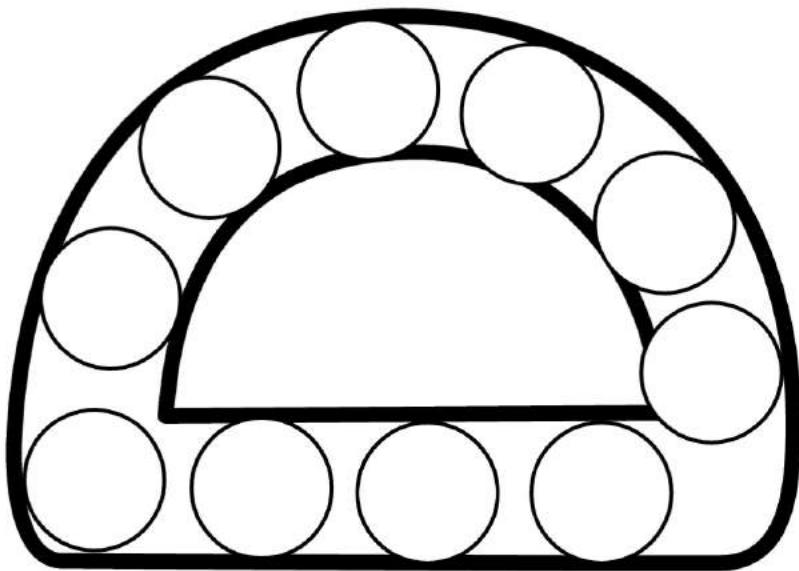
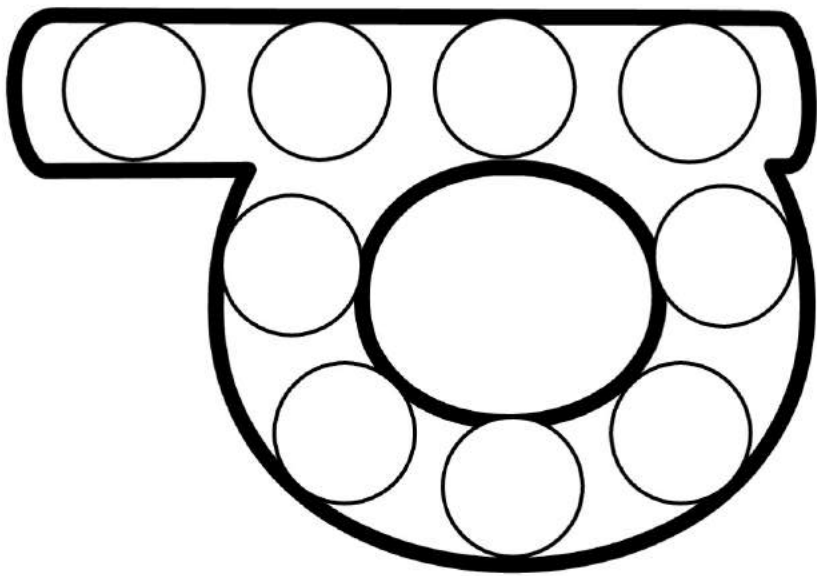

Make the letter with play dough.

# Play Dough Mat

## Letter Dd

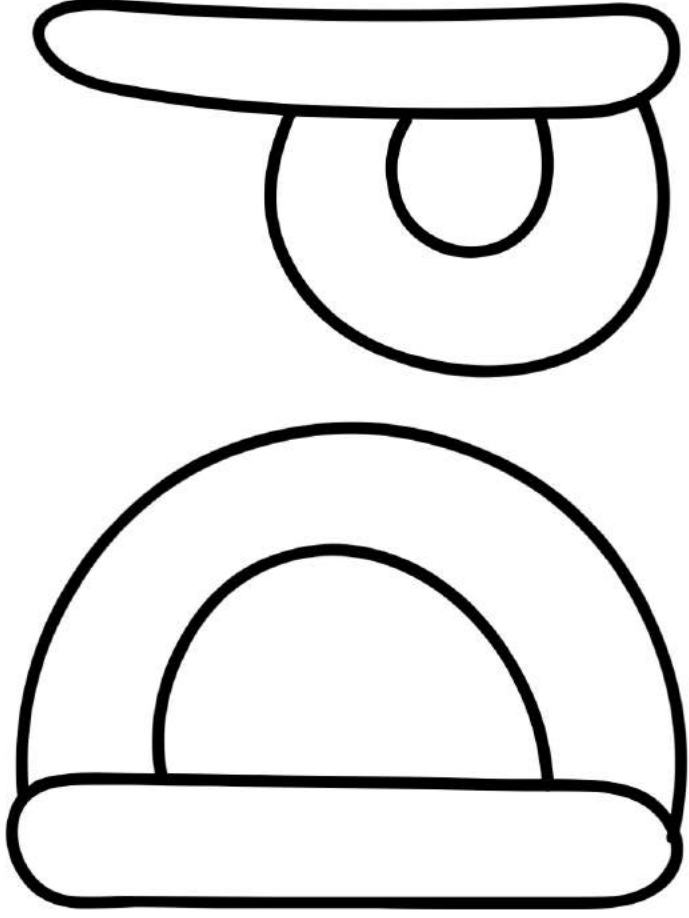

Name the pictures.

©themeasuredmom.com

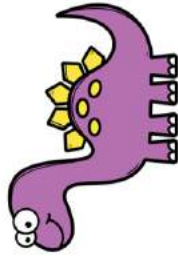

dinosaur



donut



dolphin



dog

Cover the matching letters.

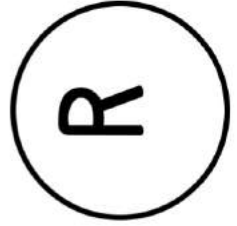
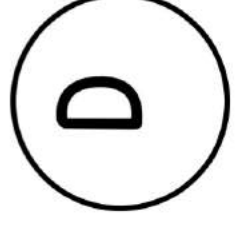
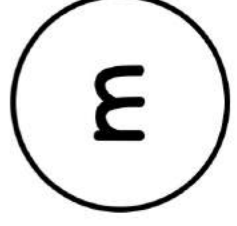
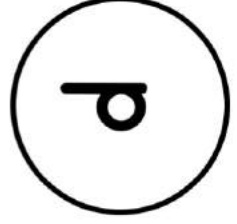
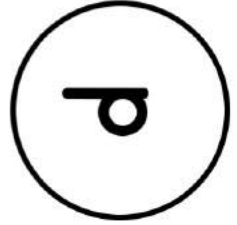
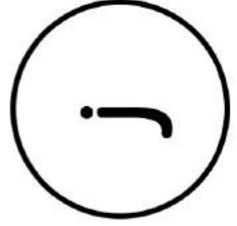
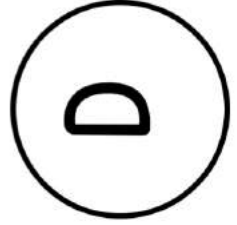

Make the letter with play dough.

# Play Dough Mat

## Letter Dd

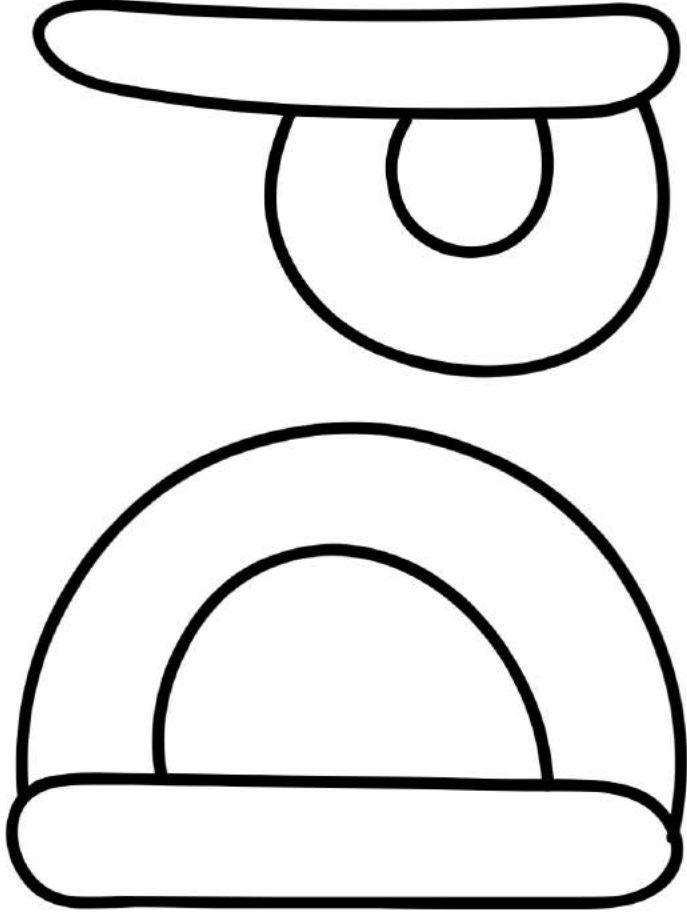

Name the pictures.

©themeasuredmom.com



dinosaur



donut



dolphin



dog

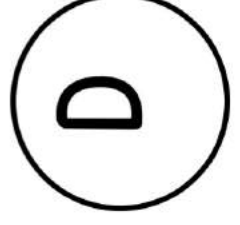
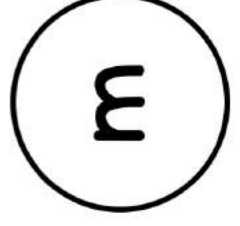
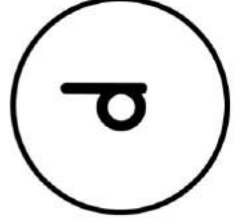
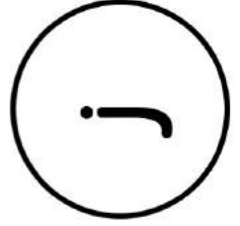
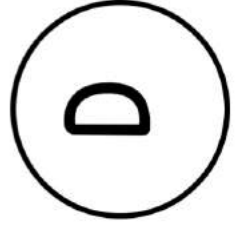

Cover the matching letters.

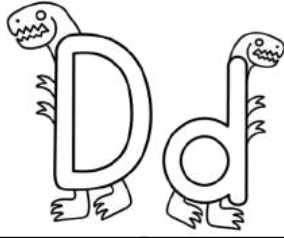

Does it begin with d?

Name \_\_\_\_\_



	
---	--

©themeasuredmom.com

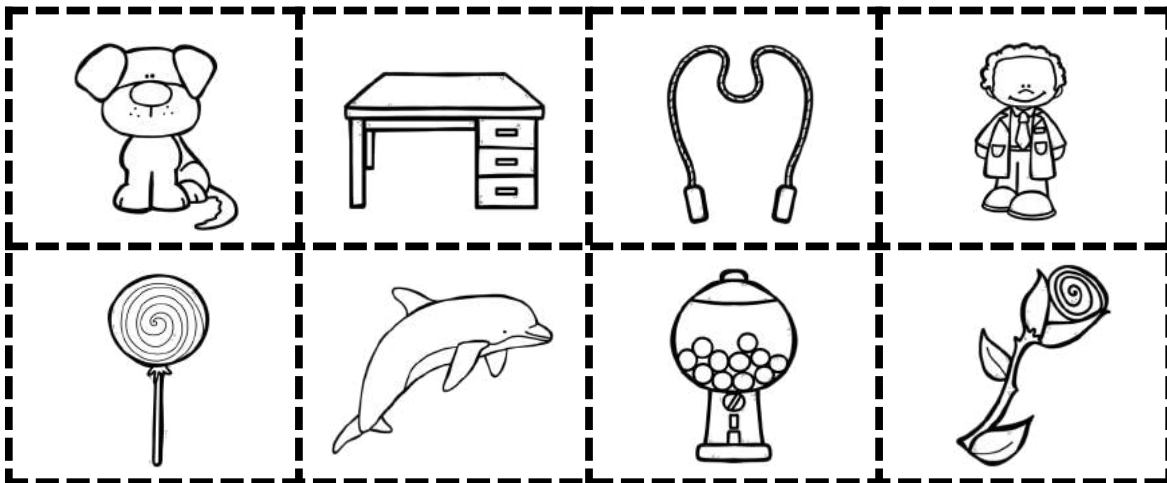

Name \_\_\_\_\_

Trace & Write.

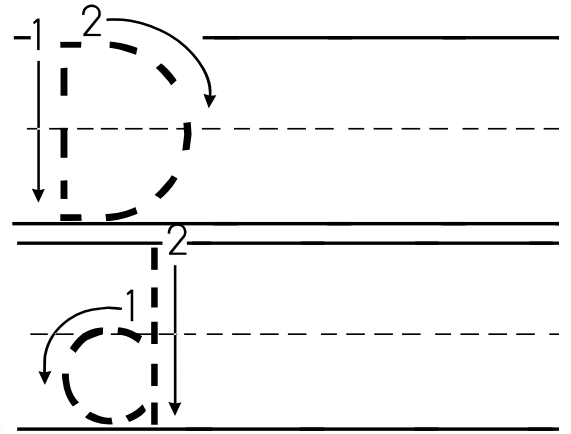
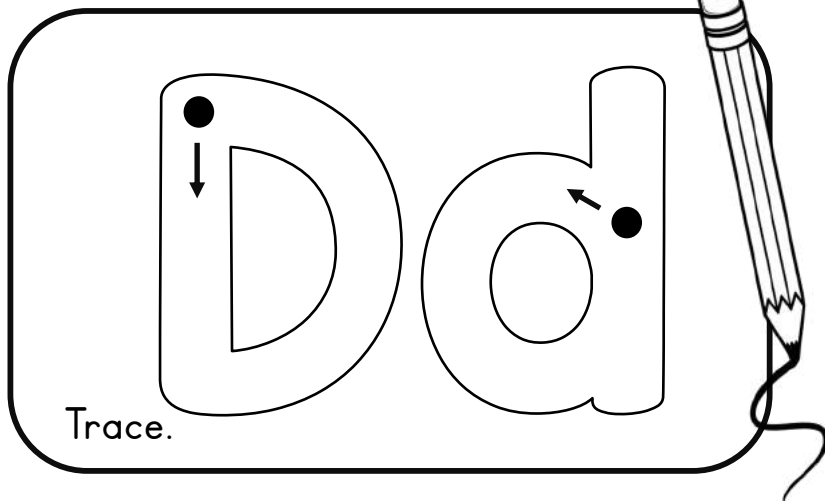

Trace.

Color the pictures that start with d.

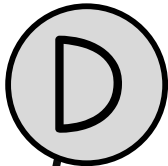
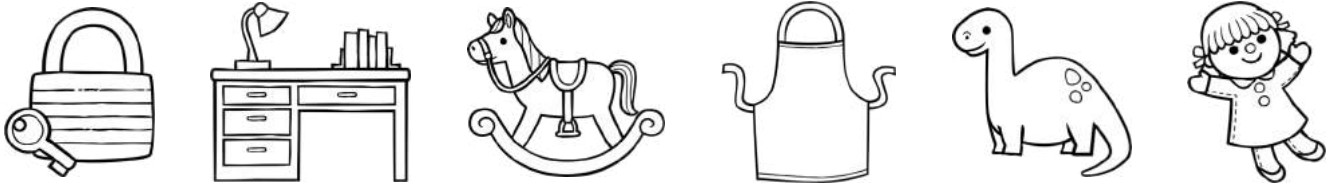

Dot the D's.

D B R  
E D F  
D D Y  
H D D

Dot the d's.

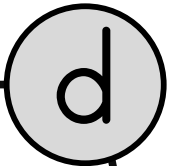

t d g  
u d d  
d p b  
m d d



# Trace it! Letter d

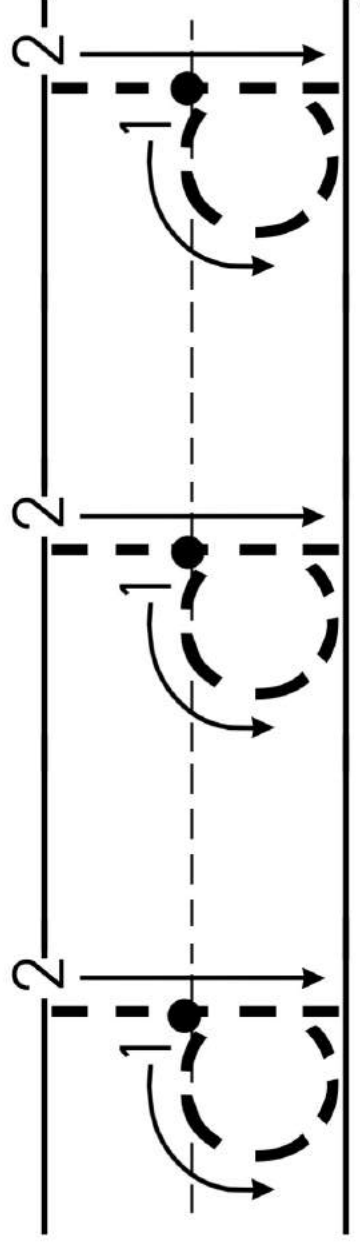
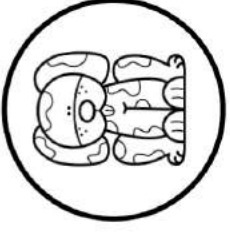
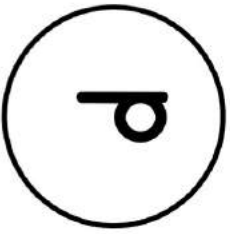
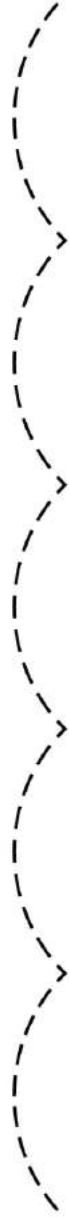
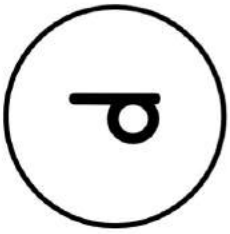
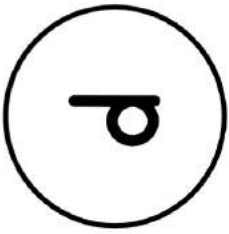
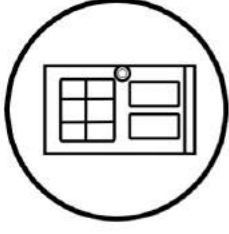
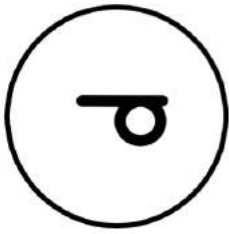



# Letter Dd Trace and Color

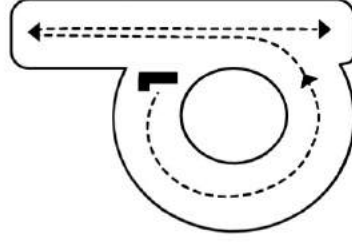
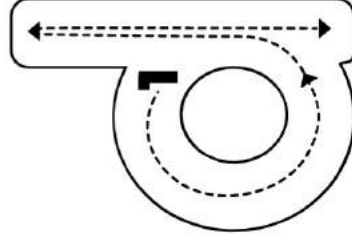
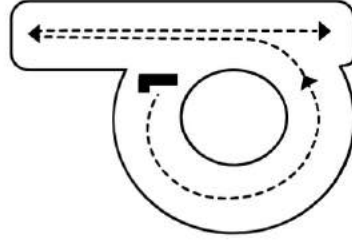
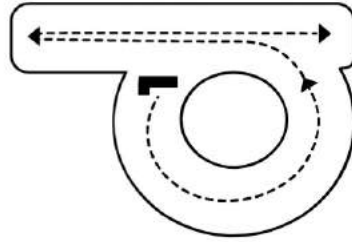
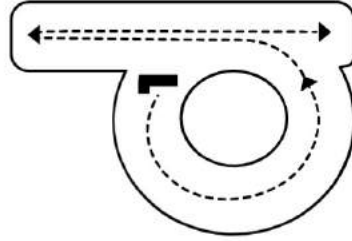
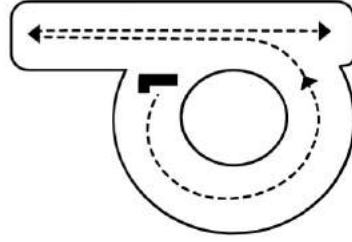
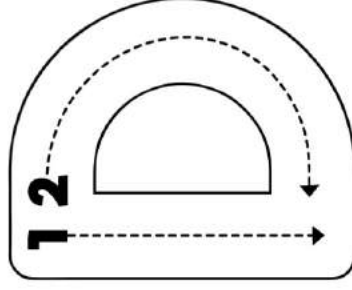
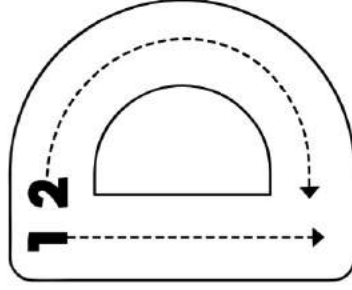
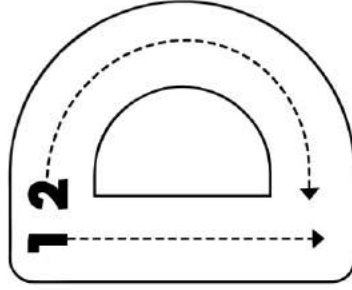
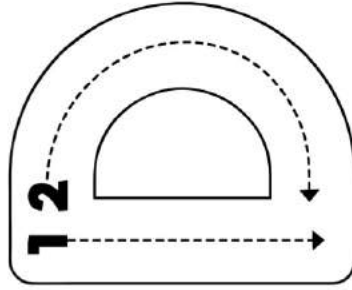
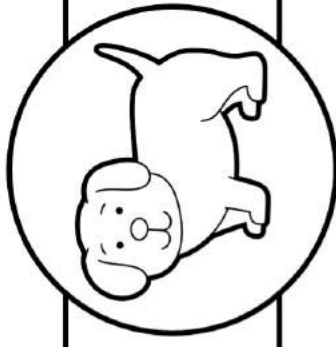

Color the pictures whose names begin with Dd.

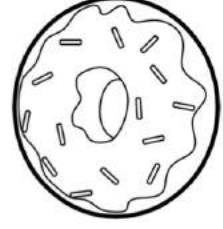
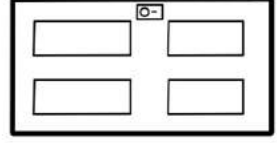
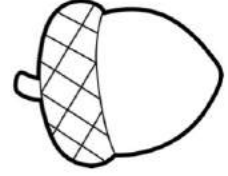
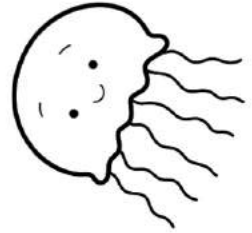

# Letter Dd Sort

D

d

D

d

D

D

d

D

d

D

d

d

D

D

# Letter d Sound Cover

Say the name of each picture. Listen to the first sound.  
Does it start with /d/? Cover or color it.

